

Commonwealth of Massachusetts

Direct Vision Study

Current Fleet Analysis and Potential Safety Criteria

Alyssa Brodeur, Juwon Drake, Eric Englin, Alexander K Epstein, PhD, Hannah Pannell,
and Sarah Yahoodik, PhD



Photo credit: Volpe

July 2024

DOT-VNTSC-MADOT-24-01

Prepared for:

Massachusetts Department of Transportation

massDOT
Massachusetts Department of Transportation

U.S. Department of Transportation
Volpe Center

Notice

This document is disseminated in the interest of information exchange. The United States Government assumes no liability for the contents or use thereof.

These recommendations represent the best technical judgement of U.S. DOT Volpe Center staff based on their independent and objective technical analysis and expertise and are not to be misconstrued as statements of U.S. DOT policy, MassDOT policy, or guidance.

Reference to any specific company, products, processes, or services by trade name, trademark, manufacturer, or otherwise in the report does not constitute or imply its endorsement or recommendation by the Volpe Center.

| REPORT DOCUMENTATION PAGE | | | <i>Form Approved</i> <i>OMB No. 0704-0188</i> | | |
|---|-----------------|-----------------|---|------------------------------|---|
| Public reporting burden for this collection of information is estimated to average 1 hour per response, including the time for reviewing instructions, searching existing data sources, gathering and maintaining the data needed, and completing and reviewing this collection of information. Send comments regarding this burden estimate or any other aspect of this collection of information, including suggestions for reducing this burden to Department of Defense, Washington Headquarters Services, Directorate for Information Operations and Reports (0704-0188), 1215 Jefferson Davis Highway, Suite 1204, Arlington, VA 22202-4302. Respondents should be aware that notwithstanding any other provision of law, no person shall be subject to any penalty for failing to comply with a collection of information if it does not display a currently valid OMB control number. PLEASE DO NOT RETURN YOUR FORM TO THE ABOVE ADDRESS. | | | | | |
| 1. REPORT DATE (DD-MM-YYYY) July 2024 | | 2. REPORT TYPE | | 3. DATES COVERED (From - To) | |
| 4. TITLE AND SUBTITLE Commonwealth of Massachusetts Direct Vision Study: Current Fleet Analysis and Potential Safety Criteria | | | 5a. CONTRACT NUMBER | | |
| | | | 5b. GRANT NUMBER | | |
| | | | 5c. PROGRAM ELEMENT NUMBER | | |
| 6. AUTHOR(S) Alyssa Brodeur, Juwon Drake, Eric Englin, Alexander K Epstein, PhD, Sarah Yahoodik, PhD, Hannah Pannell | | | 5d. PROJECT NUMBER | | |
| | | | 5e. TASK NUMBER | | |
| | | | 5f. WORK UNIT NUMBER | | |
| 7. PERFORMING ORGANIZATION NAME(S) AND ADDRESS(ES) John A. Volpe National Transportation Systems Center Office of Policy, Planning, and Environment 220 Binney Street, Kendall Square Cambridge, MA 02142 | | | 8. PERFORMING ORGANIZATION REPORT NUMBER DOT-VNTSC-MADOT-24-01 | | |
| 9. SPONSORING / MONITORING AGENCY NAME(S) AND ADDRESS(ES) Massachusetts Department of Transportation 10 Park Plaza, Suite 4160 Boston, MA 02116 | | | 10. SPONSOR/MONITOR'S ACRONYM(S) | | |
| | | | 11. SPONSOR/MONITOR'S REPORT NUMBER(S) | | |
| 12. DISTRIBUTION / AVAILABILITY STATEMENT No restrictions | | | | | |
| 13. SUPPLEMENTARY NOTES | | | | | |
| 14. ABSTRACT Direct vision is the ability of a driver to see firsthand outside their vehicle without the aid of an indirect vision device, such as mirrors or camera displays. Enhancing direct vision can significantly improve driver perception and reaction times compared to indirect vision, which is critical given that blind zones are a major factor in truck collisions with vulnerable road users (VRUs). In accordance with An Act to Reduce Traffic Fatalities (2022), in 2023 the Massachusetts Department of Transportation (MassDOT) and Volpe initiated a study to identify the range of direct vision afforded to fleet vehicle drivers and produce evidence-based recommendations stipulating a minimum acceptable level of direct vision to be met by future fleet vehicles purchased and leased by the Commonwealth. Volpe and MassDOT measured 55 vehicles across MassDOT and ten municipal fleets, as well as five vehicles at two industry events, using two methodologies and framing resulting blind zone size relative to child or adult visibility in a crosswalk or bicycle lane in accordance with the Manual on Traffic Control Devices as well as the MassDOT Separated Bike Lane Planning & Design Guide geometric standards. The technical approach and potential direct vision rating framework described in this memo are intended to support the Commonwealth of Massachusetts in measuring and managing blind zone risk, as well as informing recommendations for improving direct vision design, and could be of use to other states, cities, or municipalities interested in direct vision best practices for VRU safety. | | | | | |
| 15. SUBJECT TERMS Direct vision, blind zone, vulnerable road user, pedestrian, bicyclist, vehicle design, large truck, geometric design, and safety. | | | | | |
| 16. SECURITY CLASSIFICATION OF: | | | 17. LIMITATION OF ABSTRACT | 18. NUMBER OF PAGES | 19a. NAME OF RESPONSIBLE PERSON |
| a. REPORT | b. ABSTRACT | c. THIS PAGE | | 64 | 19b. TELEPHONE NUMBER (include area code) |
| No restrictions | No restrictions | No restrictions | | | |

Acknowledgments

The authors wish to thank the Massachusetts Department of Transportation (MassDOT) for sponsorship of this work, for arranging access to fleet vehicles, and for collaboration in data collection and processing, with special thanks to the Lab @ MassDOT including Kris Carter, Jaclyn Youngblood, Grace Coffelt, Hadar Sachs, and Julia Camacho. Thank you to the MassDOT operations team that made vehicles available to study, including Scott Wilson, Robert Buckley, and Joe Suppa. Thank you to the ten municipal partners, Cambridge, Everett, Gardner, Falmouth, Lynn, Medford, Needham, Somerville, Waltham, and Westfield who raised their hand to have their fleets be part of this study. The authors appreciate the partnership of Becky Mueller and her team at the Insurance Institute for Highway Safety in developing and sharing the open-source blind zone assessment software used in this study. The team also thanks Lou Whiting for graphic design support, Ruth Esteban-Muir (NHTSA) for draft review, and staff at the ten municipalities that participated and made their fleet vehicles available to the study.

Contents

| | |
|---|-----------|
| Contents..... | v |
| List of Tables | v |
| List of Figures | vi |
| 1 Introduction and Context..... | 10 |
| 1.1 What is direct vision?..... | 10 |
| 1.2 Existing direct vision standards, regulations, or programs | 11 |
| 1.3 Project context..... | 15 |
| 2 MassDOT and Municipal Fleet Analysis | 18 |
| 2.1 Fleets overview and vehicle selection | 18 |
| 2.2 Methods..... | 19 |
| 2.2.1 Data collection | 20 |
| 2.2.2 Data processing | 20 |
| 2.2.3 Data representation | 22 |
| 2.3 Results..... | 25 |
| 3 Applying the Study..... | 31 |
| 3.1 Minimum direct vision criteria | 31 |
| 3.2 Countermeasures for low-vision trucks..... | 37 |
| 3.3 Future exploration: area-based and volume-based methods of evaluating direct vision | 40 |
| 3.4 Incorporating direct vision in procurement | 44 |
| 3.4.1 Document and Language Options | 44 |
| 3.4.2 Proposed Reporting Method | 45 |
| 3.5 Future work..... | 47 |
| 4 Appendix..... | 53 |
| 4.1 Data collection SOP..... | 53 |
| 4.2 Data processing details..... | 58 |
| 4.3 An Act to Reduce Traffic Fatalities..... | 62 |

List of Tables



| | |
|---|----|
| Table 1. Total vehicles measured by Fleet..... | 19 |
| Table 2. Vulnerable road user dimensions based on anthropometric sources | 24 |
| Table 3. Distances to vulnerable road users forward and on passenger side of driver, aggregated by vehicle weight category..... | 30 |
| Table 4. Proposed direct vision rating system based on standard crosswalks and buffered bike lanes | 32 |

List of Figures

| | |
|---|----|
| Figure 1: View from the driver's seat of an International HV 513. Direct vision of the environment is shaded green (unobstructed view through the windows), indirect vision areas are shaded purple (mirrors and camera display unit), and the blind zone areas are shaded in orange (hood, A and B pillars, and door)..... | 10 |
| Figure 2. Illustration of different truck cab designs. | 11 |
| Figure 3. Direct Vision Standard operator guidance. | 13 |
| Figure 4. Tfl Direct Vision Standard guidance showing driver-side, passenger-side, and forward visibility for a 1-star, 3-star, and 5-star rated vehicle..... | 13 |
| Figure 5. UN Regulation 167: visible line length to each side representing the intersection of the sightlines assessment area. | 14 |
| Figure 6. Visuals from the TSR Direct Vision Measurement Kit, including the diagram for “Step 3: Recording Measurements” (left) and the diagram for the “Direct Vision Scoring Methodology” (right). | 15 |
| Figure 7. MassDOT and Volpe team collecting data using standardized eye point rig and camera. | 20 |
| Figure 8. Example shapefile of postprocess NVP point cloud output from OGRE. | 21 |
| Figure 9. Manual passenger side NVP determination (grid and y-axis label are in meters) | 22 |
| Figure 10. Distance-based blind zone representation of trucks by Tfl for adult VRUs (top) and cyclist VRUs (bottom). Y-axis units are millimeters. | 23 |
| Figure 11. Forward distance (in feet) at which adults and elementary school children are first visible to drivers in measured heavy-duty vehicles. | 26 |
| Figure 12. Forward distance (in feet) at which adults and elementary school children are first visible to | |

| | |
|--|----|
| drivers in measured medium-duty vehicles. | 27 |
| Figure 13. Forward distance (in feet) at which adults and elementary school children are first visible to drivers in measured light-duty vehicles. | 28 |
| Figure 14. Passenger-side distance (in feet) at which adults and elementary school children are first visible to drivers in measured heavy-duty vehicles..... | 28 |
| Figure 15. Passenger-side distance (in feet) at which adults and elementary school children are first visible to drivers in measured medium-duty vehicles..... | 29 |
| Figure 16. Passenger-side distance (in feet) at which adults and elementary school children are first visible to drivers in measured light-duty vehicles. | 29 |
| Figure 17. Nearest point at which an adult and child are visible to a driver at a standard crosswalk and stop bar overlaid with a five-star rating system for measured heavy-duty vehicles..... | 33 |
| Figure 18. Nearest point at which an adult and child are visible to a driver at a standard crosswalk and stop bar overlaid with a five-star rating system for measured medium-duty vehicles. | 34 |
| Figure 19. Nearest point at which an adult and child are visible to a driver at a standard crosswalk and stop bar overlaid with a five-star rating system for measured light-duty vehicles. | 35 |
| Figure 20. Nearest point at which an adult and child are visible to a driver at a buffered bike lane overlaid with a five-star rating system for measured heavy-duty vehicles. | 35 |
| Figure 21. Nearest point at which an adult and child are visible to a driver at a buffered bike lane overlaid with a five-star rating system for measured medium-duty vehicles (top) and light-duty vehicles (bottom)..... | 36 |
| Figure 22. Overview of countermeasures from Transport for London Direct Vision Standard (for more details and specifications, see: https://content.tfl.gov.uk/hgv-safety-permit-guidance-for-operators-entering-london.pdf) | 37 |
| Figure 23. Diagram of BSIS’s VRU detectable range (for more details and specifications. | 38 |
| Figure 24. Diagram of MOIS’s VRU detectable range (for more details and specifications..... | 39 |
| Figure 25. Pre-collision speeds and stopping distances, highlighting low-speed crash regime relevant to blind zone crashes between VRUs and large vehicles; Montreal approach to assess blind zone and visible area within 10 meters. | 40 |
| Figure 26. Blind zone comparison at ground of high vision and low vision Class 8 trucks (top: 2024 Dennis Eagle Proview; bottom: 2014 International Workstar 7600). Dennis Eagle Proview has 165 | |

| | |
|--|----|
| square meters of blind zone area at the ground level within a 20 meter radius; International Workstar 7600 has 285 square meters of blind zone area at the ground level..... | 41 |
| Figure 27. Blind zone area (square meters) at child shoulder height within a 10-meter radius of driver.. | 42 |
| Figure 28. Blind zone area (square meters) at adult shoulder height within a 10-meter radius of driver. . | 43 |
| Figure 29. Percentage of ground visible within a 10-meter radius of the driver. | 43 |
| Figure 30. Proposed near-term cone method of direct vision reporting for bidders. | 46 |
| Figure 31. Setup for 3-foot and 4-foot cone method of blind zone measurement. | 46 |
| Figure 32. Illustrations of different geometric designs at intersections and crosswalks: a) protected intersection, b) raised crosswalk, c) near-side traffic signals, and d) advance stop line. | 48 |
| Figure 33. MassDOT Trucking Network, with layers shown for truck exclusions. | 49 |
| Figure 34. MassDOT Potential for walkable trips on MassDOT roads (2022 update)..... | 49 |
| Figure 35. MassDOT potential for everyday walking on MassDOT roads. | 50 |
| Figure 36. Potential for Everyday Bicycling map on MassDOT and all roads (top: Eastern MA; bottom: zoom in around Cambridge-area)..... | 50 |
| Figure 37. Example of swept path visibility safety analysis for a design vehicle through an intersection that could use data from studies such as this one to model blind zone risk to people outside of vehicles and inform geometric, engineering, or operation countermeasures. (Courtesy: AutoTURN / Transoft Solutions) | 51 |
| Figure 38. Steering column placement for data collection. | 53 |
| Figure 39. Seat adjustment control buttons..... | 54 |
| Figure 40. Laser being used to identify the exact mid-point for seat, which will be used for rig placement and data collection. | 54 |
| Figure 41. Rig placed in driver seat..... | 55 |
| Figure 42. Rig with placement directions for seatback arrangement. | 55 |
| Figure 43. Close-up of rig with phone installed for measurement. | 56 |
| Figure 44. Overhead view showing the different distance calculations recorded during data collection process..... | 56 |

Figure 45. Image showing how to prepare vehicle for data collection process.....57

Figure 46. Example image at 0 degrees forward from driver eyepoint.57

Figure 47. Rig shown at close range to show the method to rotate and line up the phone into the rig. ..58

Figure 48. Aggregated images of the forward field of view for one vehicle.58

Figure 49. Image at 0 degrees where the right side of driver A pillar to midway across front hood is annotated.59

Figure 50. Image at -30 degrees where the left side of driver a pillar plus mirror is annotated.59

Figure 51. Image at -60 degrees where the annotation finishes the rest of driver window. Note that this may need to go to -90 or -120 degrees for some vehicles.60

Figure 52. Image at 30 degrees where the annotation finishes the driver hood with some overlap and left side of passenger A pillar.60

Figure 53. Image at 60 degrees where the entire passenger window is annotated.61

Figure 54. Raw output of nearest visible points on the ground around the vehicle. These are further processed to remove duplicate data points and aggregate into a single polygon shapefile of the vehicle blind zone.61

I Introduction and Context

I.1 What is direct vision?

Direct vision is the ability of a driver to see firsthand outside their vehicle without the aid of an indirect vision device, such as mirrors or camera displays. In contrast, indirect vision is the ability of a driver to see outside their vehicle through mirrors or camera displays. Direct vision enables eye contact between a driver and a vulnerable road user (VRU) near the vehicle; indirect vision generally does not.



Figure 1: View from the driver's seat of an International HV 513. Direct vision of the environment is shaded green (unobstructed view through the windows), indirect vision areas are shaded purple (mirrors and camera display unit), and the blind zone areas are shaded in orange (hood, A and B pillars, and door).

Blind zones around a vehicle can be made visible through indirect vision, however drivers' perception and reaction time is significantly faster through direct vision. According to published research, when drivers have direct vision of a pedestrian, they can react in 0.7 seconds, or 50% faster, than when they can see the same pedestrian through indirect vision.¹

Blind zones have been identified as the second leading cause of truck-pedestrian crashes in the UK,² and in the United States approximately one-fourth of truck-involved VRU fatalities consist of vision-related low-speed maneuvers³. Additionally, National Highway Traffic Safety Administration data for non-traffic crashes indicate an increase from 225 apparent VRU frontover fatalities in 2012 to 543 such fatalities in

¹ <https://content.tfl.gov.uk/road-safety-benefits-of-direct-vs-indirect-vision-in-hgv-cabs-technical.pdf> "Exploring the Road Safety Benefits of Direct vs Indirect Vision in HGV Cabs: Direct Vision vs Indirect Vision: A study exploring the potential improvements to road safety through expanding the HGV cab field of vision"

² https://link.springer.com/chapter/10.1007/978-3-030-20503-4_39

³ <https://rosap.ntl.bts.gov/view/dot/20427/Share> "Prioritizing improvements to truck driver vision"

2021, in which front blind zones may be expected to be a contributing factor.⁴

A 2016 Loughborough University study for Transport for London, the London transportation agency, concluded, “the height of the cab above the ground is the key vehicle factor which affects the size of direct vision and indirect vision blind spots. The design of window apertures and the driver location in relation to these window apertures can reduce the size of the identified blind spots. i.e., two different vehicle designs with the same cab height can have different results for blind spot size due to window design and driver seat location.”⁵

In a North American context, the prevalence of conventional cab trucks, in which the engine is forward of instead of under or behind the driver, introduces an additional variable. A 2021 Volpe analysis of crashes between VRUs and privately operated waste and demolition debris trucks in New York City tested the hypothesis that a tall hood would be associated with frontover crashes, which occur when the driver accelerates forward from a stop and strikes a person in front of the vehicle. Of the 43 analyzed fatal crashes, at least ten were found to be start-from-stop, visibility-related crashes. All ten involved conventional cab vehicles, whereas none involved a cabover truck.⁶ It should be noted that the cabovers in the NYC study generally had lower cabs heights than some trucks operated in Europe and the UK. As a limitation, the analysis did not provide insight on the propensity of different cab types to be involved in turning crashes, as information on window apertures and driver location in the cab was not available.



Figure 2. Illustration of different truck cab designs.

1.2 Existing direct vision standards, regulations, or programs

Multiple standards and regulations have been developed globally to address visibility in varying vehicle classes.

Originally published in 2006 and revised in 2017, ISO Standard 5006:2017 applies to earth-moving

⁴ Based on “forward moving vehicles” in “non-traffic crashes,” i.e., crashes in parking lots, driveways, and other locations not on public roadways. <https://crashstats.nhtsa.dot.gov/Api/Public/Publication/812311>, <https://crashstats.nhtsa.dot.gov/Api/Public/ViewPublication/813539>

⁵ <https://content.tfl.gov.uk/understanding-direct-and-direct-vision-from-hgvs-summary.pdf>

⁶ <https://www.nyc.gov/assets/dcas/downloads/pdf/fleet/Safe-Fleet-Transition-Plan-Private-Vehicle-Crashes-and-Safety-Technology-December-2021.pdf>

machines with seated operators and provides visibility performance criteria and a test method to determine acceptability.⁷ The ISO standard details indirect visibility devices that may be used to meet the visibility criteria if the measured direct visibility is inadequate for proper, effective, and safe operation of the machine.

Starting in 2017, Volpe researchers held technical exchanges with Transport for London (TfL) and their researchers at Loughborough University and the University of Leeds on direct and indirect vision. The exchanges included discussion of the findings in TfL's reports Understanding Direct and Indirect Driver Vision in Heavy Goods Vehicle (HGVs)⁸ and Exploring the Road Safety Benefits of Direct vs Indirect Vision in HGV Cabs.⁹

In 2021, in a first of its kind program, TfL and the Mayor of London implemented a Direct Vision Standard (DVS) as part of the city's Vision Zero approach.¹⁰ This standard applies to all vehicles over 12 tonnes (26,455 lb) entering London and assigns a star rating from zero to five to all HGVs. The star rating is based on measurements of a driver's direct vision through the HGV windows.

All vehicles entering London are required to obtain a free HGV safety permit. Vehicles that are rated zero stars (or less than 3 stars starting October 2024)¹¹ must be retrofitted with additional safety equipment to be able to obtain their safety permit. These retrofit requirements include equipment to improve indirect vision such as mirrors, cameras or sensors, warnings for VRUs of vehicle maneuvers, and systems to minimize the physical risks of an HGV-VRU crash. According to the program, additional retrofitting options will be added for zero star rated vehicles to obtain a safety permit after periodic review of additional technology and safety equipment options on the market for HGVs. According to TfL, fatal collisions where vision is a factor have fallen by 75% following the introduction of DVS.¹²

⁷ <https://www.iso.org/standard/45609.html>

⁸ <https://content.tfl.gov.uk/understanding-direct-and-indirect-vision-in-hgvs-full-technical-report.pdf>

⁹ <https://content.tfl.gov.uk/road-safety-benefits-of-direct-vs-indirect-vision-in-hgv-cabs-technical.pdf>

¹⁰ <https://tfl.gov.uk/info-for/deliveries-in-london/delivering-safely/direct-vision-in-heavy-goods-vehicles>

¹¹ <https://content.tfl.gov.uk/tfl-dvs-guidance-for-operators-2023-acc.pdf>

¹² <https://tfl.gov.uk/info-for/media/press-releases/2023/june/tfl-and-london-councils-progress-plans-to-further-improve-lorry-safety-in-london>

around the front and sides of vehicles. Since its adoption by UNECE in November 2022,¹⁶ 57 countries (including the EU) across four continents have applied UN R167 (June 2023).¹⁷

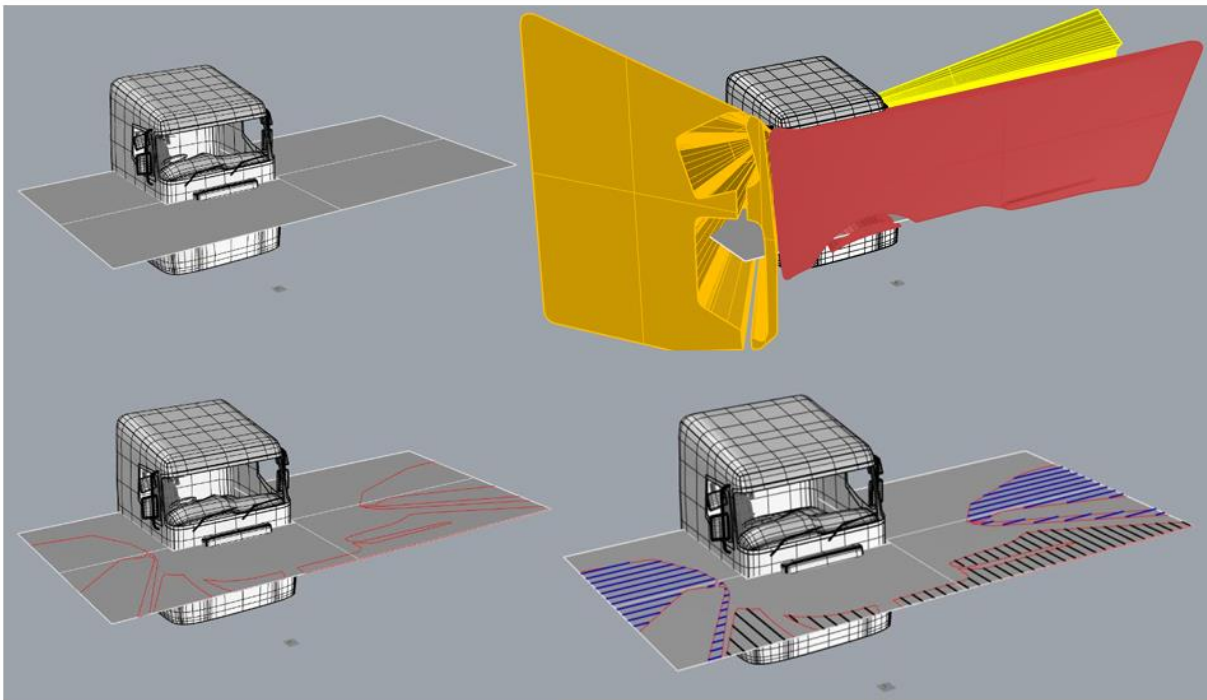

Figure 5. UN Regulation 167: visible line length to each side representing the intersection of the sightlines assessment area.

According to a 2006 study of commercial truck visibility, U.S. “regulatory requirements for truck driver vision are minimal. The only standard that bears directly on driver fields of view is Federal Motor Vehicle Safety Standard (FMVSS) 111, which regulates mirror systems. Trucks over 10,000 lb are required to have planar mirrors with an area of at least 323 cm² on each side of the cab. Direct vision is unregulated.”¹⁸ The Tfl and UN regulations discussed above are not applicable to vehicles sold in the U.S. and thus offer no direct means of blind zone comparison between vehicle makes and models in the U.S. market.

The Boston Public Health Commission and Boston Transportation Department approached Volpe in 2022 to assess the blind zone risk of the City’s fleet as well as the blind zones of alternative vehicle models. Volpe measured blind zones in 21 vehicles across three City of Boston Departments, evaluating blind zone size relative to child or adult visibility in a crosswalk or bicycle lane in accordance with Manual on Uniform Traffic Control Devices and Boston Transportation Department geometric standards.

¹⁶ <https://unece.org/sustainable-development/press/unece-adopts-two-new-regulations-improve-safety-vulnerable-road-users>

¹⁷ <https://treaties.un.org/doc/Publication/MTDSG/Volume%20I/Chapter%20XI/XI-B-16-167.en.pdf>

¹⁸ <https://rosap.nhtl.bts.gov/view/dot/20427/Share> “Prioritizing improvements to truck driver vision.” Note that aftermarket device and certain other visual obstruction placement on commercial vehicle windshields is regulated by a Federal Motor Carrier Safety Regulation, however it does not apply to the original windshield or truck cab design. <https://www.ecfr.gov/current/title-49/subtitle-B/chapter-III/subchapter-B/part-393/subpart-D/section-393.60>

The direct vision rating framework in that study followed the TfL star rating approach and employed a relatively simple, distance-based methodology suitable for in-field rather than laboratory data collection.

In 2023, the road safety nonprofit Together for Safer Roads (TSR) partnered with public and private sector fleets to develop a North American Direct Vision Star Rating System¹⁹ aimed at private sector fleets procuring new trucks. TSR developed the rating system, which is consistent with the Boston methodology, through a combination of user research and insights from drivers and fleet managers during ride-alongs in Boston and New York. Like the Boston and TfL DVS approach, TSR’s rating system quantifies the distance at which VRUs can be seen from the cab on a zero-to-five-star scale. In addition, TSR produced mailable Direct Vision Measurements Kits²⁰ with tools and instructions for fleet managers to help identify vehicles with poor visibility that may require retrofitting or replacement.

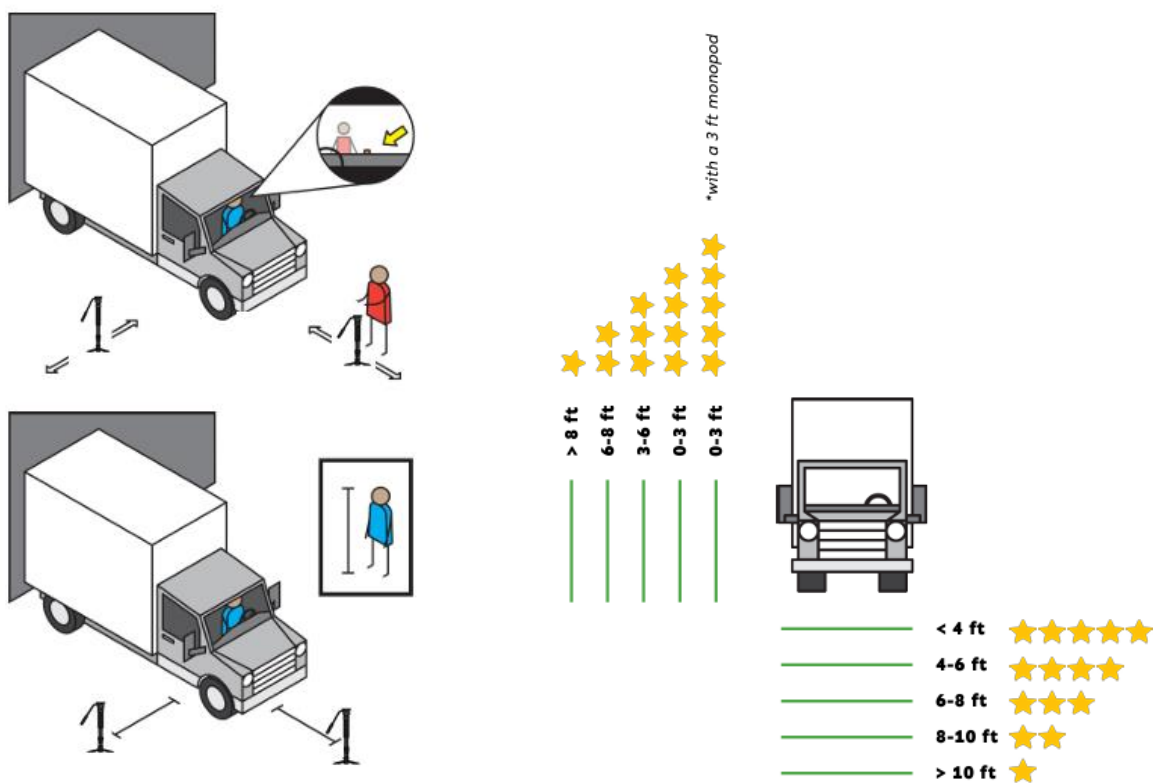

Figure 6. Visuals from the TSR Direct Vision Measurement Kit, including the diagram for “Step 3: Recording Measurements” (left) and the diagram for the “Direct Vision Scoring Methodology” (right).

1.3 Project context

In the Commonwealth of Massachusetts Acts, chapter 358, An Act to Reduce Traffic Fatalities (2022),

¹⁹ <https://togetherforsaferroads.org/our-work/direct-vision-star-rating-system/>

²⁰ <https://togetherforsaferroads.org/wp-content/uploads/sites/341/TSRs-5-Star-Direct-Vision-Rating-System - Digital-Guide.pdf>

amends MGL c. 90 § 7 to state that MassDOT and Volpe shall complete “a study of the direct vision performance of vehicles [...]. The study shall identify the range of direct vision afforded to drivers in this population of vehicles and produce evidence-based safety recommendations stipulating a minimum acceptable level of direct vision to be met by future applicable vehicles purchased and leased by the Commonwealth.”²¹ MassDOT and Volpe initiated work on this study in July 2023.

Prior to this legislation, the Boston Public Health Commission and Boston Transportation Department, recognizing that poor direct vision of certain vehicles has contributed to VRU fatalities that the City’s Vision Zero Task Force regularly reviews,²² approached Volpe in 2022 to assess the blind zone sizes of its own fleet vehicles as well as the blind zones of alternative vehicle models outside of its fleet. This baselining and best practice development effort was intended as an initial step to contemplate how specifications on direct vision could be developed and applied in a U.S. city context. The potential ratings that emerged from the vehicle blind zone measurements were intended to be meaningful and rigorous, yet simple and streamlined enough to be actionable for potential near-term City of Boston policy outcomes.

Prior to this effort, TSR convened a private-sector fleet-focused direct vision workshop in February 2023. The workshop sought to develop among fleet industry participants the requirements for and design of a prototype direct vision rating system. At the workshop, participants identified the requirements for a rating system as trust, interpretability, ability to communicate to a wide audience (including the general public), and a standardized approach across states or cities. The participants generally agreed that a star-rating system, similar to the TFL DVS, would be an intuitive rating system. Volpe attended, documented, and considered the results of this workshop in the development of both the Boston report and the present MassDOT study.

This applied research effort also builds on the direct vision and human factors research of Volpe projects sponsored by Office of the Assistant Secretary of Transportation for Research (OST-R), the Santos Family Foundation, and collaboration with the Olin College of Engineering. In a 2022 fixed-base driving simulator study, Volpe evaluated scenarios in which drivers of a low-vision and a high-vision commercial truck model, both currently available on the market, could see people entering and exiting a crosswalk in front of them during a red light. In none of the 45 scenarios did the drivers of the high-vision cabs strike the pedestrian in front of their vehicle. However, in 39 of the 45 scenarios the drivers of the low-vision cabs struck the pedestrian. This indicated that direct vision both to the front and the sides allows drivers of high-vision cabs to refrain from striking pedestrians directly in front, a situation that is common in the signalized intersection crosswalk scenarios tested in this study. As part of these efforts, the [VIEW app](#) and driver safety simulation research have been produced, and a stakeholder group of national and international SMEs as well as USDOT modal agencies have been engaged for coordination.

The technical approach and potential direct vision rating framework described in this memo are intended to support the Commonwealth of Massachusetts in measuring and managing blind zone risk.

²¹ Statute: <https://malegislature.gov/Laws/SessionLaws/Acts/2022/Chapter358>

²² For example: <https://www.wcvb.com/article/pedestrian-struck-killed-by-vehicle-in-boston-on-wednesday/14472785#>

The State has various policy pathways that it may consider leveraging to do so, for example vehicle procurement and any contracts or permitting involving the use of vehicles.

This report may also be of use for other states, cities, or municipalities who are interested in direct vision best practices for VRU safety. The procurement process varies by locality so the implementation will vary as well, but the practices outlined in this report can be used to inform the development of procurement practices for other localities.

2 MassDOT and Municipal Fleet Analysis

2.1 Fleets overview and vehicle selection

MassDOT has over 2,400 vehicles in their fleet, comprising 919 light-duty (pickups and vans), 724 medium-duty (flatbeds, box trucks, street sweepers), and 760 heavy-duty (dump, plow, garbage) vehicles on Massachusetts roads. In addition, most Massachusetts municipalities and agencies have their own unique fleets. Ten municipalities and two additional Commonwealth agencies agreed to participate in the study, reporting at least 1,150 vehicles. However, it is important to note that most municipalities did not report their entire fleet list. Instead, they reported vehicle details (make, model and year) of a subset of their fleet, prioritizing vehicles over 10,000 lbs. This resulted in inconsistent interpretation and reporting. Therefore, metrics provided should only be treated as an estimate.

Volpe and MassDOT measured 55 vehicles across MassDOT and ten municipal fleets, as well as five vehicles across two industry events, for a grand total of 60 study vehicles. The Volpe team worked with MassDOT to prioritize the vehicle measurements of the most common makes and models of vehicles in the municipal and MassDOT fleets. In addition, MassDOT surveyed Commonwealth agencies and contractors to ensure that a sample of commonly used vehicles were measured. Table 1 reports the number of vehicles measured in each municipality's and agency's fleet. In addition, the table reports the number of vehicles in each fleet that have the same make and model as those that were measured. Only vehicles in the fleet with model year of 2015 or later were included; in a few instances, older model years prior to 2015 were measured because of availability of the vehicles. Those earlier model years were in the same generation and thus shared cab design with models after 2015. This table aggregates vehicles across years 2015-2024, so the analysis assumes that vehicles of the same make and model in this period are going to remain generally similar regardless of year. However, vehicle redesigns do happen and can result in significant changes in direct vision, a limitation of the study.

Department of Conservation and Recreation (DCR) and Department of Corrections (DOC) also supplied fleet inventories. The percent of model year (MY) 2015 or newer vehicles consistent with those measured in this study is 92.7% and 74.0%, respectively. On average, the study vehicles are representative of a majority, 52.9%, of the reported large vehicles across the Commonwealth and municipal fleets.

Table 1. Total vehicles measured by Fleet.²³

| Municipality/Agency | Number of vehicles measured in each fleet | Number of similar vehicles MY2015 or newer in reported fleet | Total reported vehicles in fleet list MY2015 or newer | Similar vehicles MY2015 or newer measured as % of reported fleet |
|---|---|--|---|--|
| Fleet 1 | 3 | 51 | 57 | 94.7% |
| Fleet 2 | 3 | 32 | 93 | 34.4% |
| Fleet 3 | 4 | 8 | 9 | 88.9% |
| Fleet 4 | 4 | 18 | 51 | 35.3% |
| Fleet 5 | 4 | 31 | 149 | 20.8% |
| Fleet 6 | 3 | 17 | 69 | 24.6% |
| Fleet 7 | 6 | 48 | 80 | 60.0% |
| Fleet 8 | 4 | 32 | 71 | 45.1% |
| Fleet 9 | 5 | 20 | 55 | 36.4% |
| Fleet 10 | 4 | 44 | 130 | 33.8% |
| MassDOT | 14 | 152 | 214 | 71.0% |
| Department of Corrections | - | 37 | 48 | 92.7% |
| Department of Conservation and Recreation | - | 115 | 124 | 74.0% |
| NYC Fleet Show 2024 | 4 | - | - | - |
| MassDOT Innovation Conference 2024 | 1 | - | - | - |
| Grand total | 59 | 608 | 1150 | 52.9% |

2.2 Methods

MassDOT and Volpe collaboratively collected and processed the data for this study, cross-verifying results to ensure consistent outputs.

²³ Although this study measured 59 total vehicles, some vehicles of the same make and model showed very similar blind zones, so these vehicles have been de-duplicated in the results. The results are based on 54 total vehicles.

2.2.1 Data collection

The Volpe and MassDOT teams used a collectively prioritized vehicle list to coordinate several site visits from December 2023 to May 2024 to measure vehicles and take pictures. The site visits included:

- Three MassDOT facilities in Weston, Braintree, and Bridgewater;
- Ten municipalities: Cambridge, Somerville, Falmouth, Gardner, Everett, Lynn, Medford, Needham, Waltham, and Westfield; and
- Two industry events: New York City Fleet Show and MassDOT Innovation Conference

Below is the general protocol for each vehicle (full procedure included in 4.1):

1. Park the vehicle in a reasonably flat surface area.
2. Set the driver seat in the standardized position.
3. Position the measurement rig²⁴ in the driver's seat to represent a 50th percentile male driver eyepoint.
4. Mount the phone into the measurement rig at the top of rig.
5. Record data about the vehicle and the camera position.
6. Capture images at every 30 degrees to cover the complete forward field of view. Images are saved and used for data processing.



Figure 7. MassDOT and Volpe team collecting data using standardized eye point rig and camera.

2.2.2 Data processing

Data processing consisted of three steps: annotation, cleaning, and calculation. Annotation required tracing vehicle photos using an open-source software package, called OGRE, developed by the Insurance Institute for Highway Safety that is available on GitHub.²⁵ The cleaning step used ArcGIS to remove points and join the geometric data into a single shapefile. The calculation step brought the shapefile into

²⁴ Designed and prototyped by Insurance Institute for Highway Safety, and replicated for this study.

²⁵ Visibility Study repository on IIHS Github: https://github.com/IIHS-HLDI/visibility_study

Python and calculated various vehicle blind zone metrics.

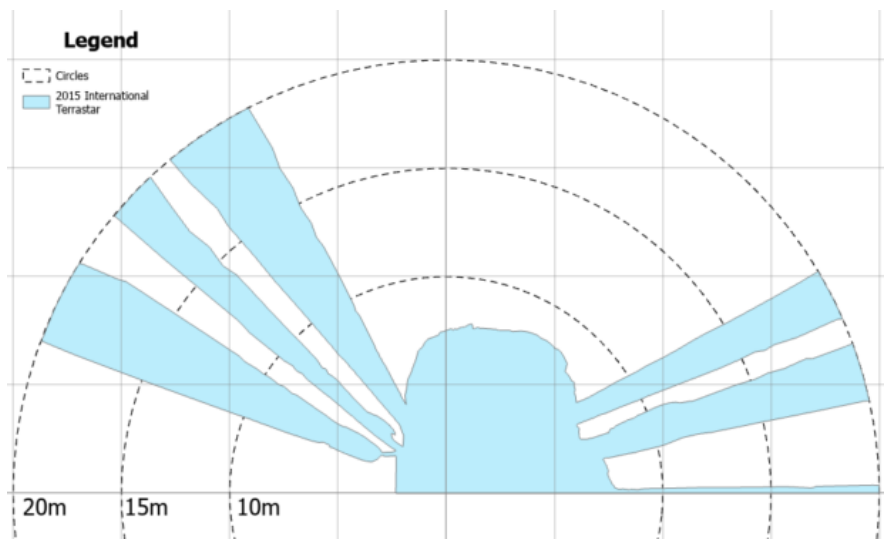

Figure 8. Example shapefile of postprocess NVP point cloud output from OGRE.

After taking the vehicle measurements and photos, the user brought the photos into a custom nearest visible point (NVP) calculation software. The user entered the vehicle measurements, and using the photos, traced the bottom edge of the field of view from the driver's eyepoint. The software then used the traces and measurements to project the NVPs on the ground around the vehicle, and the NVP coordinates were output into a table.

The table of NVP coordinates was then brought into a mapping software, such as ArcGIS, for cleaning and processing into shapefiles. Cleaning was a necessary step because the annotation step introduces significant extraneous data due to photo overlap. Iterative improvements on the annotation process reduced the cleaning burden, but the cleaning step was still necessary due to various intricacies and quirks of how the custom software used in the annotation step translated the points drawn on-screen to the projected NVPs in "real space."

Automated NVP processing

The shapefiles were then passed off to a Python script for calculation of VRU-related metrics, such as calculation of blind zone areas for VRUs and calculation of NVPs to VRUs. The Python script also generated overhead figures for each vehicle and VRU combination.

Future work should focus on automation of data processing. The annotation and cleaning steps require a high degree of human judgment and are prone to process inconsistency across users and across vehicles. Standardized processes mitigated these issues, but still presented a major time and cost burden when inconsistencies and mistakes required correction. The presence of inconsistencies and human error also necessitated extensive and careful review, presenting another time and cost burden arising from the lack of automation in data processing. The passenger side NVP was found to be especially sensitive to small variations in orientation and layout of a given vehicle model's shapefile, given the common placement of a B-pillar at or near the 90-degree direction, which generates infinite NVP distance outputs. Unusual daylight opening configurations in the passenger side door presented a further complication.

Manual NVP processing

Given the time and cost burden of automated NVP processing, a manual process was developed using the OGRE outputted point NVP point cloud. The raw point cloud, translated to center it at the driver eyepoint using the camera x and y coordinates, were plotted for each of the vehicles. The x and y intercepts of the NVP point cloud were determined by visually inspecting each plot and hovering over the point closest to each axis intercept. The input photos used for OGRE processing were also referenced to help interpret the NVP cloud. Where a B-pillar was present at 90 degrees, the coordinates of the “knee” in the shadow between the beltline and the front of the B-pillar was used, as shown in Figure 9.

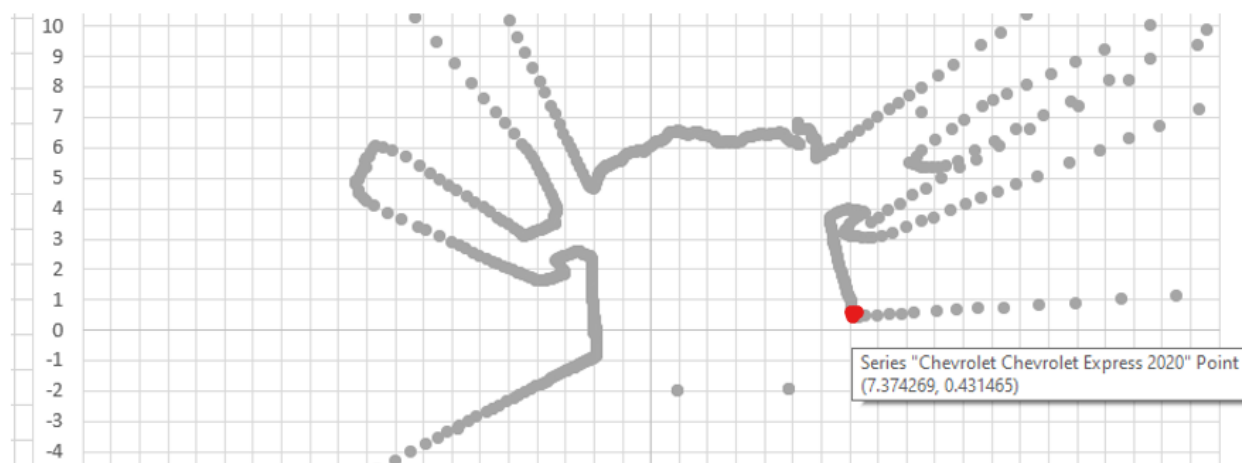

Figure 9. Manual passenger side NVP determination (grid and y-axis label are in meters)

Formulas were applied in Excel to the manually determined 0-degree and 90-degree NVP outputs combined with the eyepoint coordinates and distance to the passenger side of each vehicle to calculate the elementary school child and adult distances across the study fleet.

2.2.3 Data representation

Based on the City of Boston fleet study and in consultation with MassDOT, the project team developed two approaches that can be used to represent blind zones of vehicles in the present study. The first and primary approach relies on the distance to where a reference height person walking or biking first becomes visible in the forward and passenger directions to a driver with a standardized eye position.

The distance-based representation aligns with one way that TfL has represented direct vision assessments for trucks used in its DVS standard development. Corresponding TfL figures are shown below, with the difference that in the present direct vision study, pedestrian visibility was assessed directly forward of the driver and not to the front right.

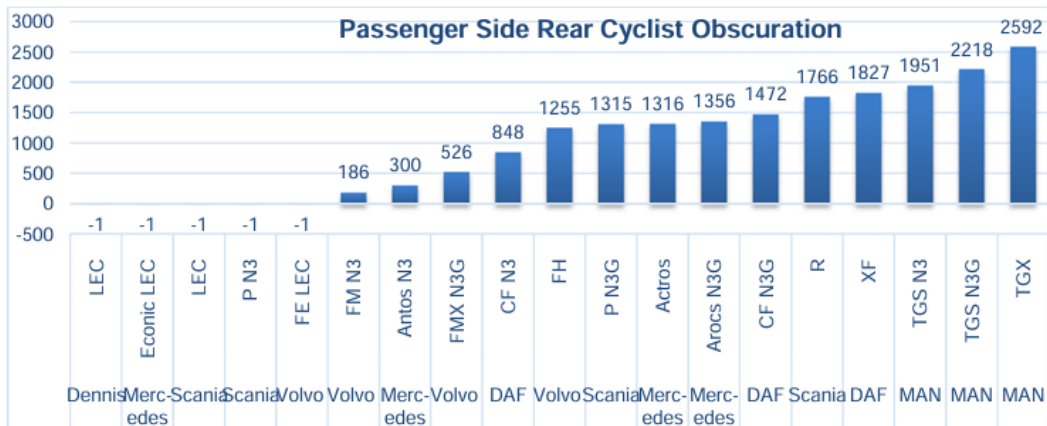
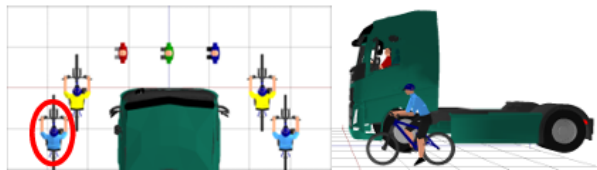
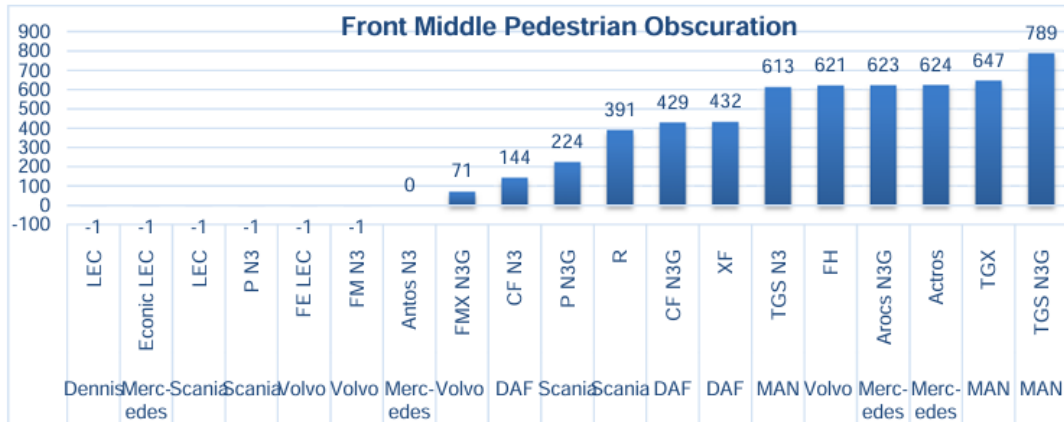
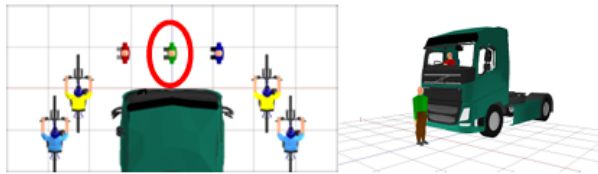

Figure 10. Distance-based blind zone representation of trucks by TfL for adult VRUs (top) and cyclist VRUs (bottom).²⁶ Y-axis units are millimeters.²⁷

The second, exploratory approach uses the area visible to the driver within the forward 180-degree field of view, within either a 10-meter or 20-meter radius, excluding the area within the vehicle’s footprint. Either the distance or area approach may be generalized to assess all passenger and commercial vehicles.

²⁶ <https://content.tfl.gov.uk/understanding-direct-and-direct-vision-from-hgvs-summary.pdf>

²⁸ Federal Highway Administration. *Manual on Uniform Traffic Control Devices*. 2009. <https://mutcd.fhwa.dot.gov/htm/2009/part3/part3b.htm>

For reference street geometry against which to benchmark blind zone extent, the project team used the Federal Highway Administration’s (FHWA) Manual on Uniform Traffic Control Devices (MUTCD) to inform dimensions for the minimum crosswalk and stop bar geometry, providing a nationally consistent reference in an intersection context. The MUTCD states that stop lines should be placed a minimum of 4 feet in advance of the nearest crosswalk line.²⁸ Additionally, the MUTCD provides guidance that a crosswalk that uses diagonal or longitudinal lines should be not less than 6 feet wide.²⁹ The standard crosswalk measurements for the analysis uses the minimum guidelines and assumes that a driver stops such that the vehicle’s front bumper is directly above the stop line.

The MUTCD offers more limited guidance on bicycle lane dimensions. The project team therefore acquired design standards from the MassDOT Separated Bike Lane Planning & Design Guide³⁰ to inform the minimum buffered or flexpost-separated bike lane dimensions, in which the painted buffer is 2 feet wide, and the bike lane is 5 feet wide. This geometry provides context for blind zone extent in the passenger side direction.

The project team incorporated person shoulder heights from U.S. anthropometric data tables.³¹ The dimensions of reference person types are summarized in Table 2.

Table 2. Vulnerable road user dimensions based on anthropometric sources

| Reference person type | Anthropometric source | Stature | Shoulder Height | Width |
|------------------------------------|---|-----------|-----------------|----------------------------------|
| Adult | 5th percentile adult female shoulder height | 60 inches | 49 inches | 16 inches |
| Wheelchair user | 5th percentile adult female shoulder height, sitting + standard wheelchair seat height | 49 inches | 39 inches | 26 inches |
| Elementary school child | 5th percentile 7yo female shoulder height | 45 inches | 37 inches | 12 inches |
| Preschool child | 5th percentile 3yo female shoulder height | 34 inches | 28 inches | 9 inches |
| Adult on bicycle | 5th percentile adult female shoulder height, sitting * cos(30 deg torso angle) + buttock height = shoulder height | 58 inches | 47 inches | 16 inches (assume staggered row) |
| Elementary school child on bicycle | 5th percentile 7yo female shoulder height, sitting * cos(30 deg torso angle) + buttock height = shoulder height | 45 inches | 35 inches | 12 inches (assume staggered row) |

²⁸ Federal Highway Administration. *Manual on Uniform Traffic Control Devices*. 2009. <https://mutcd.fhwa.dot.gov/hdm/2009/part3/part3b.htm>

²⁹ Ibid.

³⁰ <https://www.mass.gov/doc/chapter-3-general-design-considerations/download>

³¹ Anthropometric Survey of U.S. Personnel: Summary Statistics Interim Report. March 1989. <https://multisite.eos.ncsu.edu/www-ergocenter-ncsu-edu/wp-content/uploads/sites/18/2016/06/Anthropometric-Detailed-Data-Tables.pdf>

2.3 Results

The following figures summarize results for the vehicles assessed in this study. Figures 11-13 compare the forward visibility of the measured vehicles, grouped by vehicle weight category, while Figures 14-16 compare the passenger-side visibility. Vehicles are presented in each figure in decreasing order of visibility.

To facilitate more helpful comparison between fleet vehicles that may perform similar missions and could potentially be substituted, the figures are divided into light-duty, medium-duty, and heavy-duty weight classes. Consistent with FHWA classification, light-duty is defined as Class 1-2 or gross vehicle weight rating (GVWR) of 10,000 pounds or less; medium-duty is defined as Class 3-6 or 10,001 to 26,000 pounds; and heavy-duty is defined as Class 7-8 or 26,001 pounds or more.

At MassDOT's request, Volpe compared the current fleet with several new truck models available on the market, collecting this data at the MassDOT Innovation Conference (April 2024) and NYC Fleet and Equipment Show (May 2024). The following figures include these new models not in the current study fleets: Dennis Eagle ProView, Bollinger B4, REE P7C, Battle Motors LNT, and International eMV607.

The forward visibility of the study vehicles is found to range from less than 2 feet to more than 15 feet for seeing elementary school age children walking, and from 0 feet to nearly 11 feet for seeing adults walking. In the passenger side direction, visibility of the study vehicles ranges from less than 3 feet to more than 18 feet for seeing elementary school age children biking, and from 0 feet to over 14 feet for seeing adults biking. These wide ranges reflect in part the different types and sizes of vehicles included in the study, from Class 1 to Class 8. However, even within heavy, medium, and light-duty weight classes, the analysis reveals significant variation of direct vision performance across vehicles, suggesting that fleets have choices for considering best-in-class direct vision vehicles. Not all vehicles measured appear in the figures based upon processing or where multiple vehicles of the same model generation were measured; in the latter case, the oldest model years have been omitted.

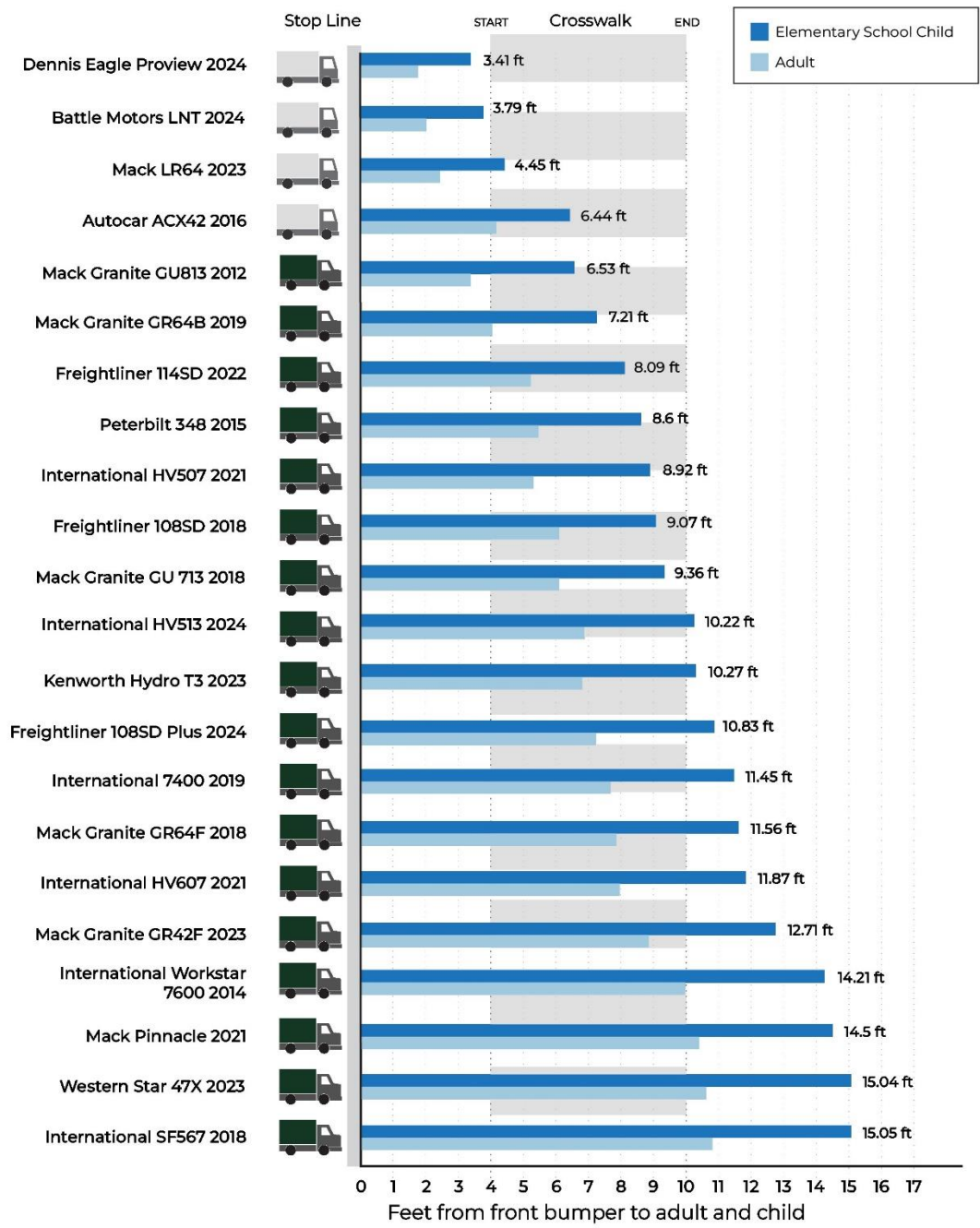

Figure 11. Forward distance (in feet) at which adults and elementary school children are first visible to drivers in measured heavy-duty vehicles.

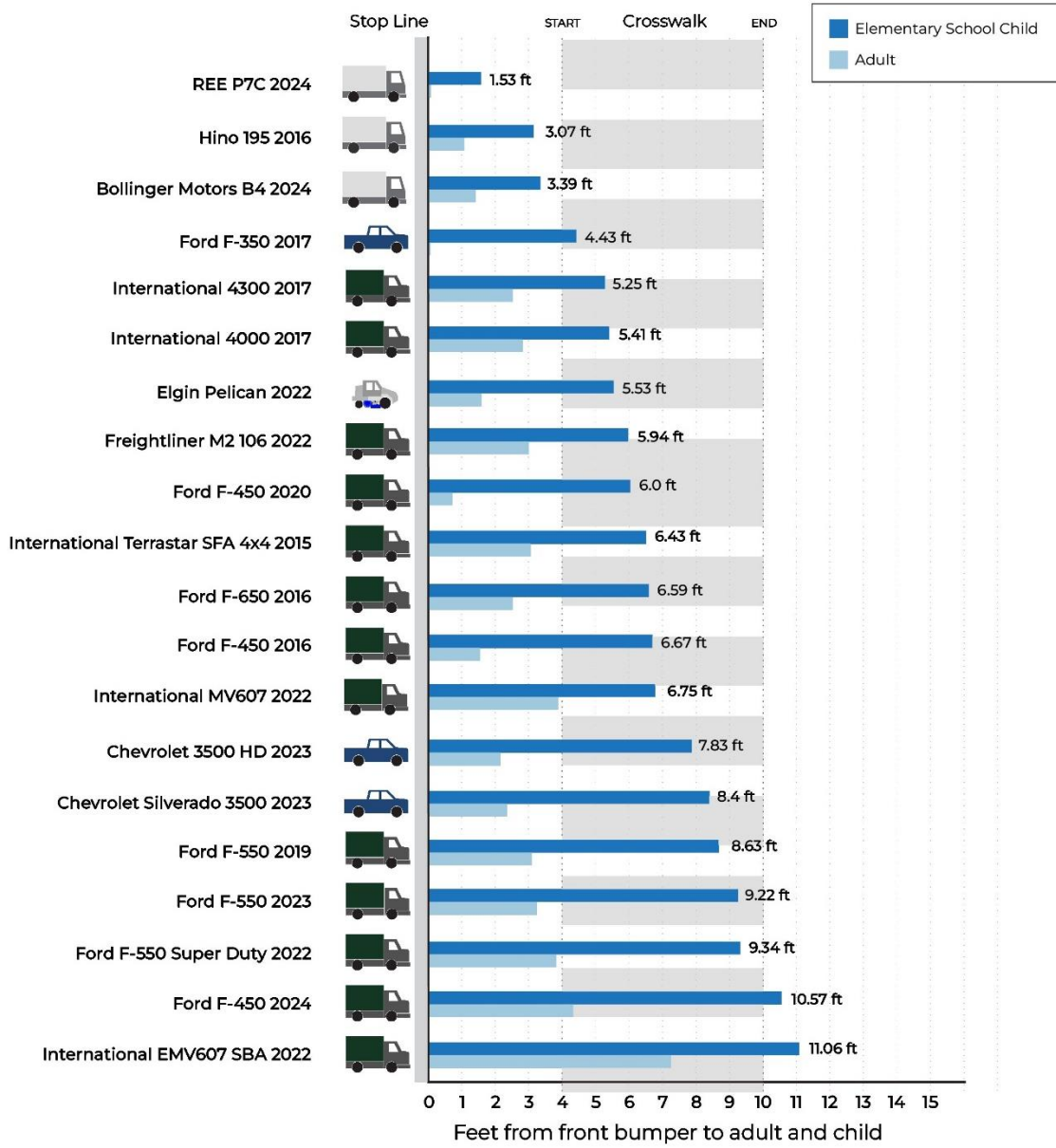

Figure 12. Forward distance (in feet) at which adults and elementary school children are first visible to drivers in measured medium-duty vehicles.

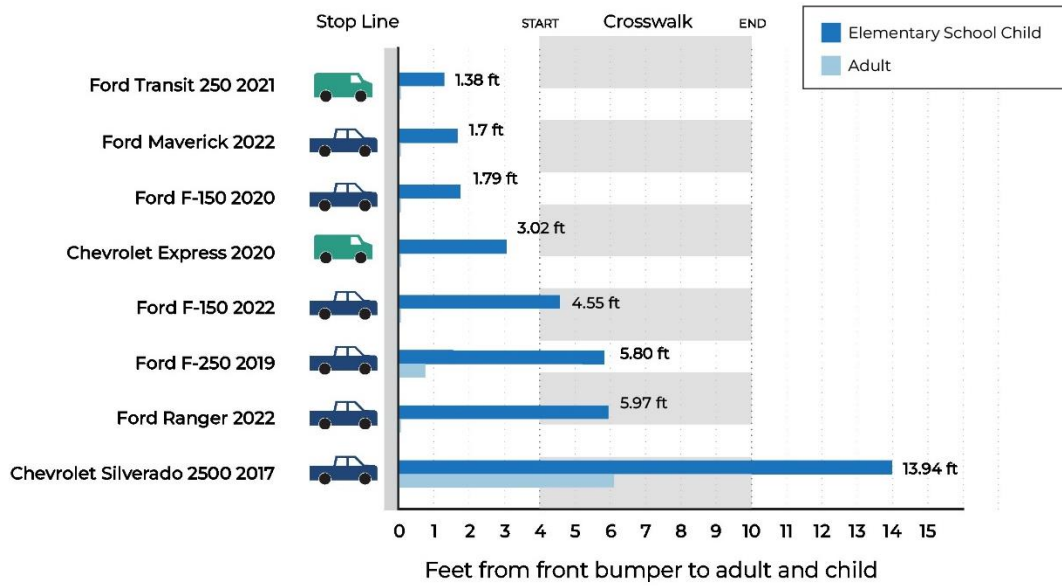

Figure 13. Forward distance (in feet) at which adults and elementary school children are first visible to drivers in measured light-duty vehicles.

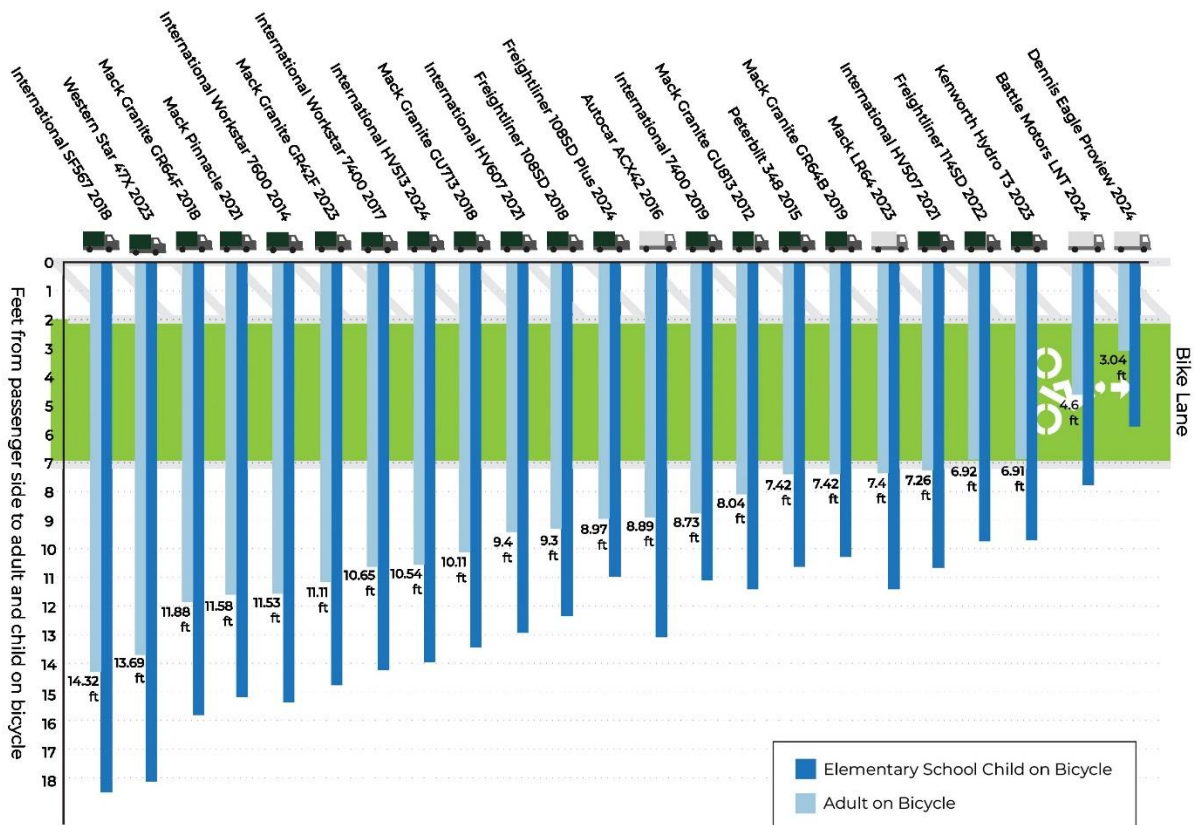

Figure 14. Passenger-side distance (in feet) at which adults and elementary school children are first visible to drivers in measured heavy-duty vehicles.

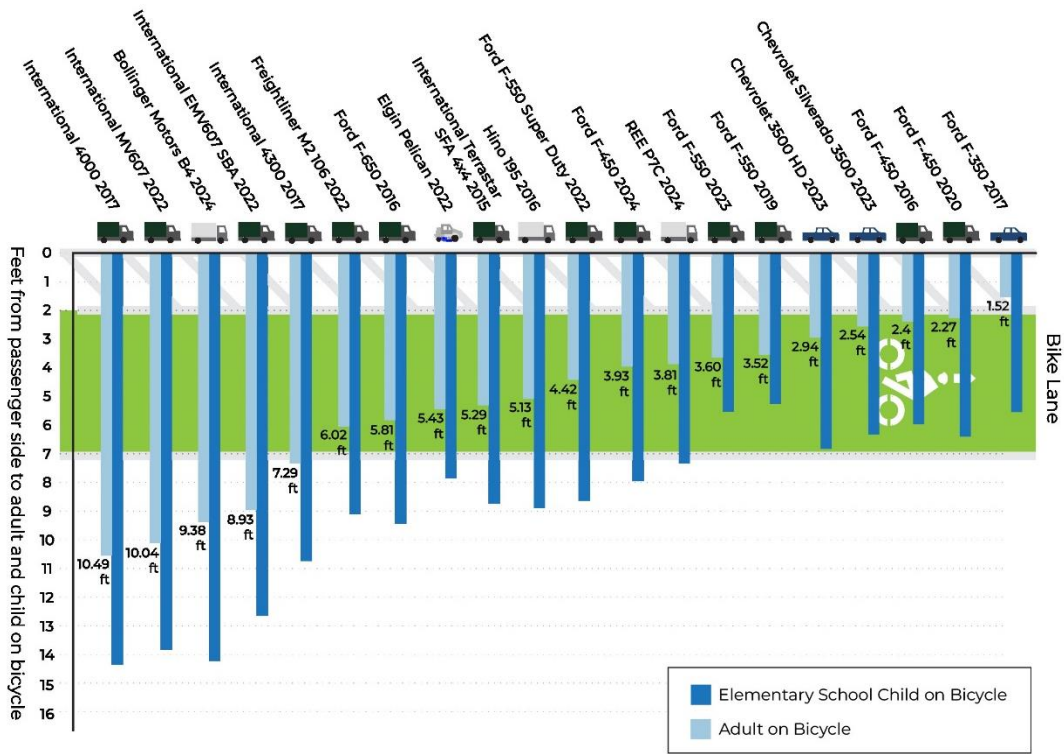

Figure 15. Passenger-side distance (in feet) at which adults and elementary school children are first visible to drivers in measured medium-duty vehicles.

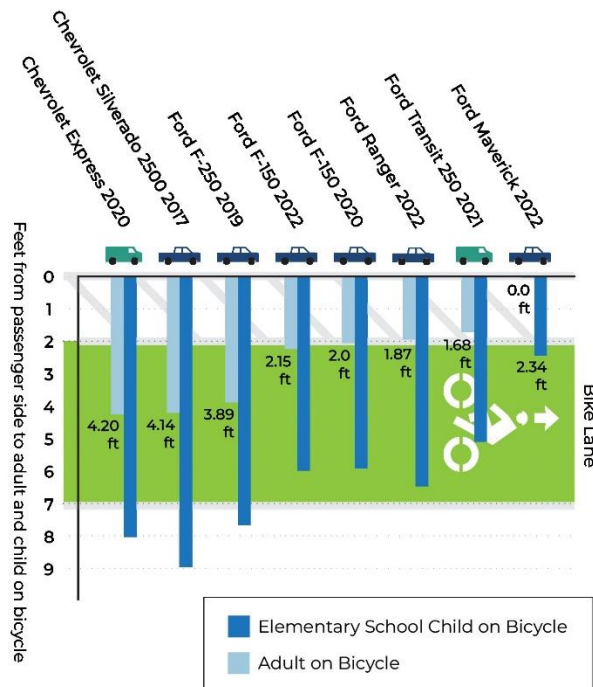

Figure 16. Passenger-side distance (in feet) at which adults and elementary school children are first visible to drivers in measured light-duty vehicles.

Key takeaways and observations about the range of ratings include:

- On average, light-duty vehicles have the highest visibility in MassDOT fleets. Medium-duty vehicles have lower visibility, and heavy-duty vehicles have the lowest visibility, as shown in Table 3. Drivers in heavy-duty vehicles can rarely see a child in a bike lane. As a general rule, downsizing vehicles can have a major impact on direct vision in a fleet.
- The most common light-duty truck in the MassDOT fleet is the Ford F-150. The 2020 model had relatively high visibility (5-stars forward, 4-stars on passenger side). The 2022 model showed lower visibility (4-stars forward, 4-stars on passenger side).
 - Within the light-duty category, the Ford Maverick displayed the highest visibility, and the Chevrolet Silverado 2500 displayed the lowest visibility.
- More research should be conducted to further understand vehicle design trends, but visibility in weight class 3 and 4 vehicles appears to be decreasing in newer generations of legacy models. In contrast, new medium-duty entrants, such as the REE P7C, appear to be designed for enhanced direct vision, and these vehicles demonstrate higher visibility, particularly forward of the driver.
- The medium-duty vehicles are highly variable, likely depending on vocational applications and configurations, such as suspension height.
 - The Ford F450 results are highly variable. Visual inspection across model years and the measured vehicles indicates a change in the hood shape, but there are also plow packages and headlights on two of the four.
- Of the heavy-duty vehicles measured, the cab-forward style tended to have higher forward visibility. Some of these vehicles had more passenger-side visibility, but this was not always the case.

Table 3. Distances to vulnerable road users forward and on passenger side of driver, aggregated by vehicle weight category.

| Vehicle weight category | Number of vehicles | Average forward distance to elementary child walking (ft) | Average forward distance to adult walking (ft) | Average passenger-side distance to elementary child on bike (ft) | Average passenger-side distance to adult on bike (ft) |
|-------------------------|--------------------|---|--|--|---|
| Light-Duty | 8 | 4.6 | 0.8 | 6.2 | 2.4 |
| Medium-Duty | 23 | 6.0 | 2.3 | 8.8 | 5.1 |
| Heavy-Duty | 24 | 10.1 | 6.7 | 12.5 | 9.1 |
| All Vehicles in Study | 55 | 7.6 | 4.0 | 10.0 | 6.5 |

3 Applying the Study

This section discusses how the Commonwealth and its municipalities can apply the results of this study.

3.1 Minimum direct vision criteria

An Act to Reduce Traffic Fatalities (c. 358, 2022) required this study to “produce evidence-based safety recommendations stipulating a minimum acceptable level of direct vision.”

Direct vision criteria that are applied in procurement or other policy are ideally clear enough to understand and communicate to a wide audience, as well as sensitive enough to segment vehicles already in service or available to fleets for purchase. Consistent with the City of Boston and TSR approach, the study team proposes a five-star scoring framework. Stakeholders, including the public, are widely familiar with this type of rating system from other contexts such as the New Car Assessment Program and are likely to understand that one star is low-performing and that five stars is high-performing. Additionally, the study team proposes aligning the star ratings based on standard street geometries and the shoulder heights of 5th-percentile-height female individuals. The rationale is that blind zones create safety risks for VRUs as a function of both a person’s height and where street geometries position a person and a vehicle in relation to each other. By assessing direct vision based on seeing the 5th percentile-height female human, as TfL has used in its approach, most of the U.S. population is accounted for.

The study team proposes separate scores for forward and passenger side visibility. Each score would align with vulnerable road user infrastructure – crosswalks for forward visibility and buffered bike lanes for passenger side visibility. This approach reflects how TfL, even though it is a volume-based assessment approach, links star ratings to sight lines for front and side vision,³² and such an approach is consistent with how the NYC Executive Order 39 of 2024³³ and the TSR direct vision rating framework³⁴ each reference direct vision criteria.³⁵

Note that the NYC Executive Order 39 effectively codifies the 3-star rating definition from Table 4 as the City of New York’s definition of a “high-vision truck”:

- **High Vision Truck:** The distance from the forward of the center of the vehicle bumper at which the driver can first see the top of a 3-foot cone shall not exceed eight feet and the distance beyond the exterior of the passenger side door at which the driver can first see the top of the 4-foot cone shall not exceed six feet.

³² <https://content.tfl.gov.uk/tfl-dvs-guidance-for-operators-2023-acc.pdf>

³³ <https://www.nyc.gov/office-of-the-mayor/news/39-003/executive-order-39>

³⁴ <https://togetherforsaferroads.org/our-work/direct-vision-star-rating-system/>

³⁵ [Direct Vision Standard and HGV Safety Permit Scheme - Transport for London \(tfl.gov.uk\)](https://www.tfl.gov.uk/road-users/high-vision-trucks)

Table 4. Proposed direct vision rating system based on standard crosswalks and buffered bike lanes

| Star rating | Forward | Passenger Side |
|-------------|--|---|
| 5 | Elementary school children and adults are visible less than 4 feet from the front of vehicle. | Elementary school children and adults are visible less than 3 feet from the passenger side of vehicle. |
| 4 | Elementary school children are visible 4-6 feet from the front of vehicle. | Adults are visible less than 3 feet from the passenger side of vehicle. |
| 3 | Elementary school children are visible 6-8 feet from the front of vehicle. | Adults are visible 3-6 feet from the passenger side of vehicle. |
| 2 | Elementary school children are visible 8-10 feet from the front of vehicle. | Adults are visible 6-8 feet from the passenger side of vehicle. |
| 1 | Elementary school children are visible more than 10 feet from the front of vehicle. | Adults are visible more than 8 feet from the passenger side of vehicle. |

The Commonwealth could adopt a consistent three-star definition of high-vision. For minimum direct vision criteria, it could potentially set two stars as the initial floor and consider raising the floor in the future, in a parallel manner as TfL has progressed since its DVS program inception.

The following figures summarize the State and municipal study fleets with overlays showing how vehicles would score according to the potential five-star rating system. Color-coded boxes reflect which vehicles would allow a median-height male driver to view a child at any point in either a crosswalk or buffered bike lane; at some but not all points; and at no point in a crosswalk.

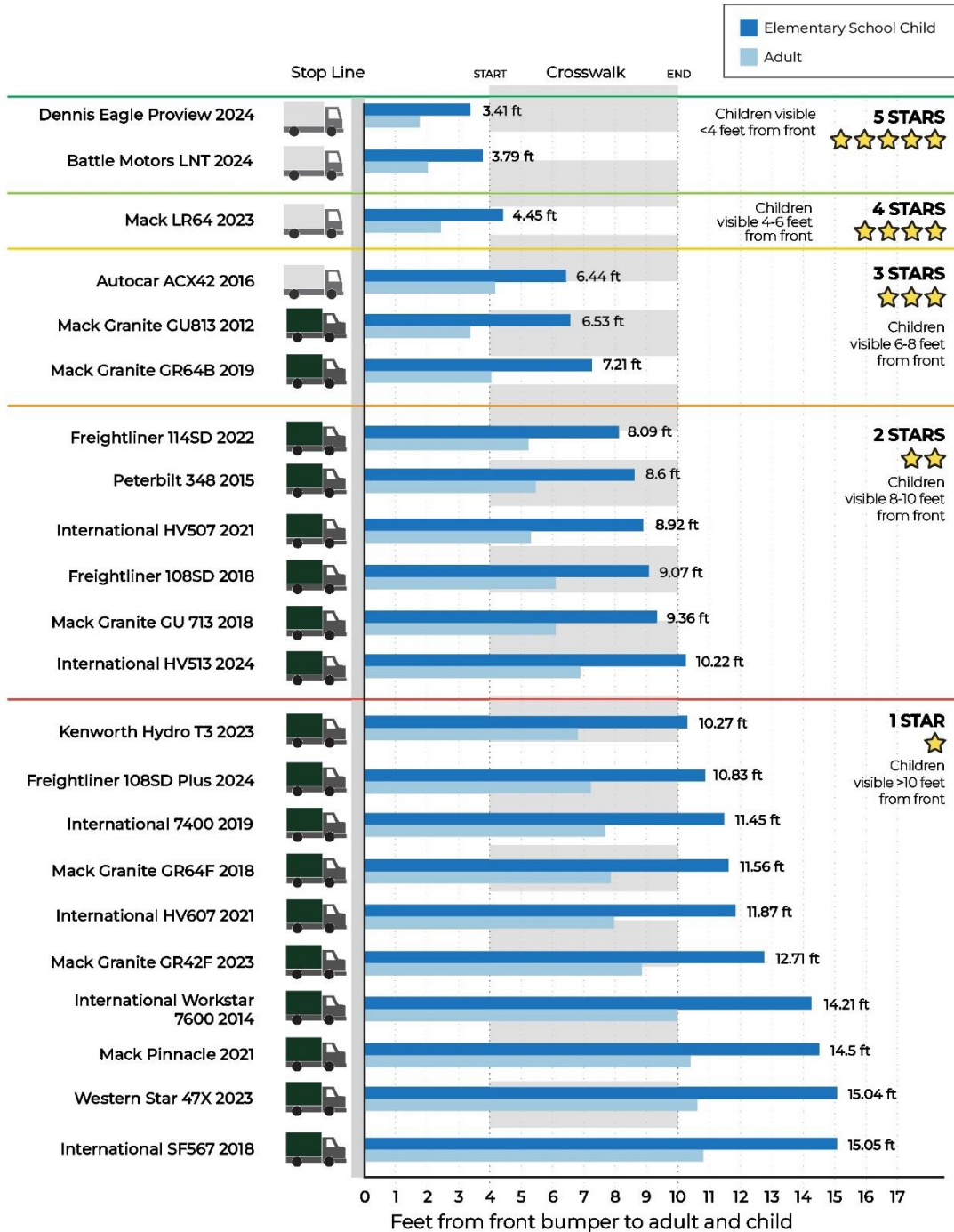

Figure 17. Nearest point at which an adult and child are visible to a driver at a standard crosswalk and stop bar overlaid with a five-star rating system for measured heavy-duty vehicles.

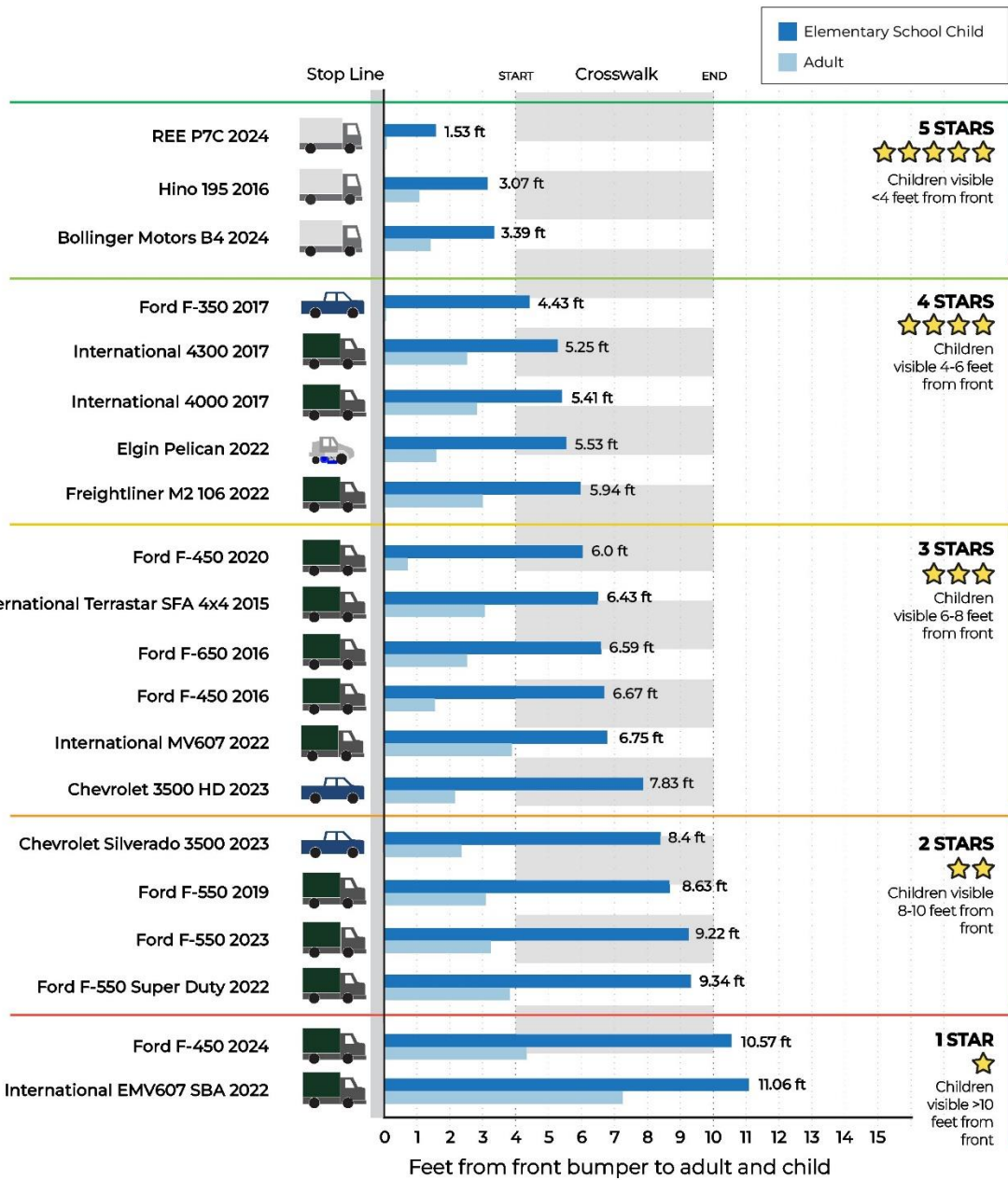

Figure 18. Nearest point at which an adult and child are visible to a driver at a standard crosswalk and stop bar overlaid with a five-star rating system for measured medium-duty vehicles.

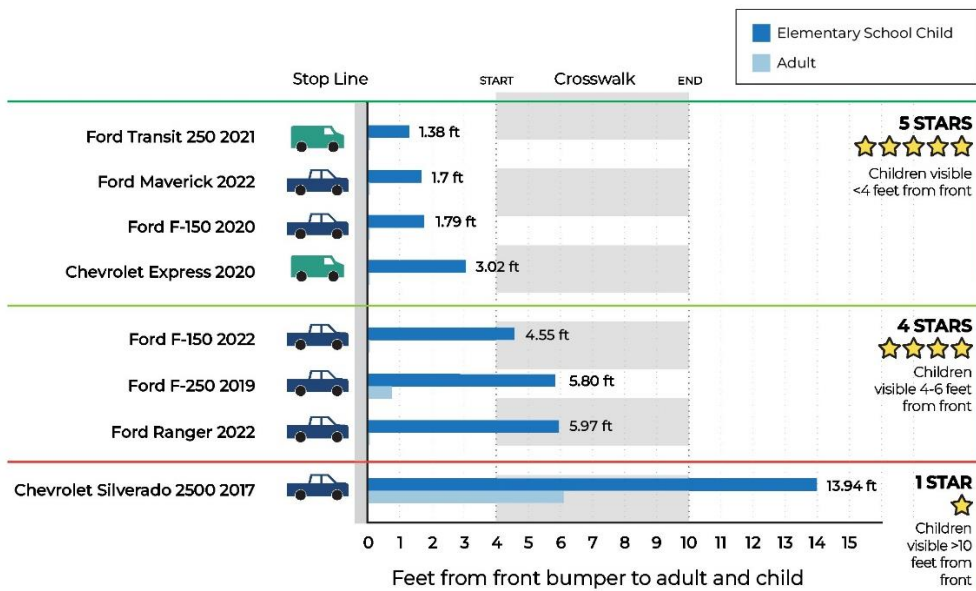

Figure 19. Nearest point at which an adult and child are visible to a driver at a standard crosswalk and stop bar overlaid with a five-star rating system for measured light-duty vehicles.

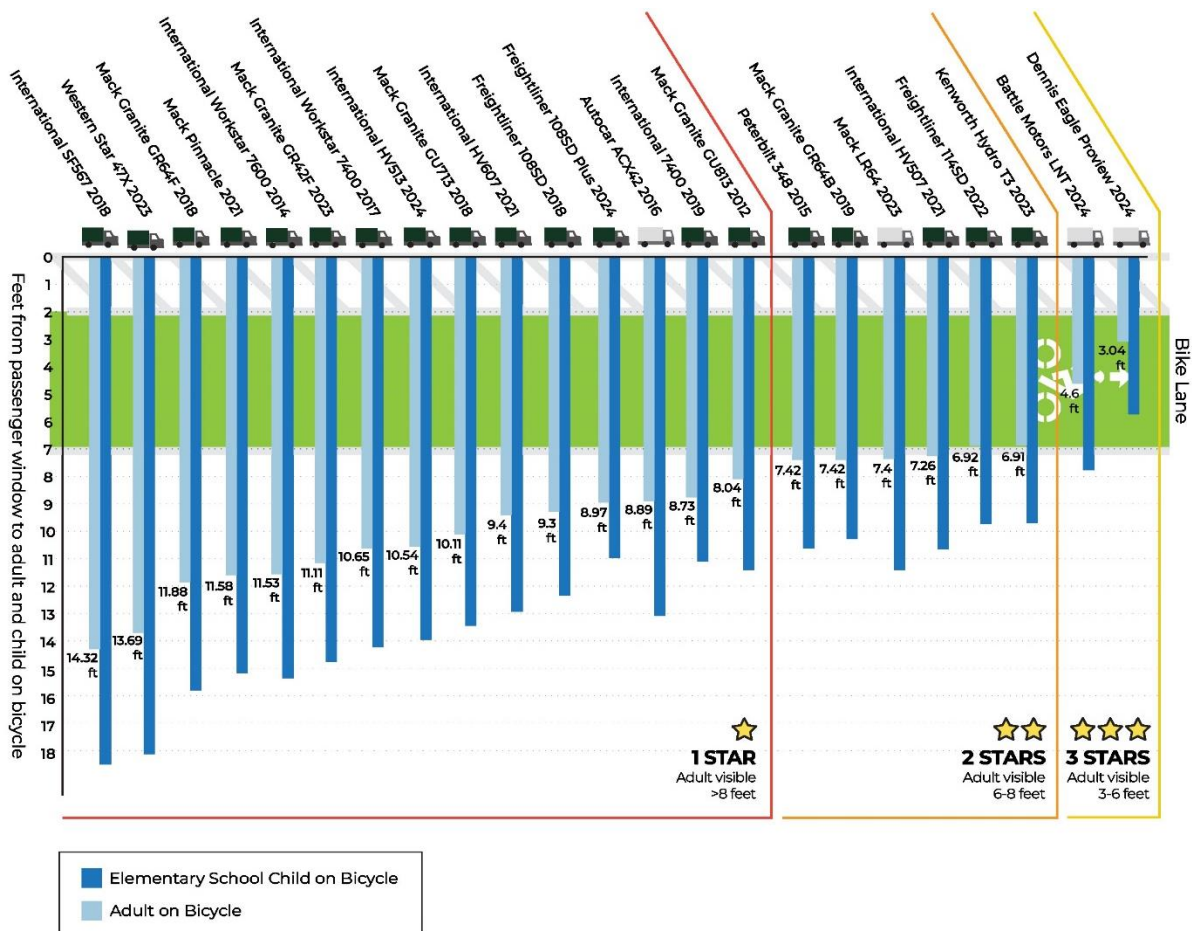

Figure 20. Nearest point at which an adult and child are visible to a driver at a buffered bike lane overlaid with a five-star rating system for measured heavy-duty vehicles.

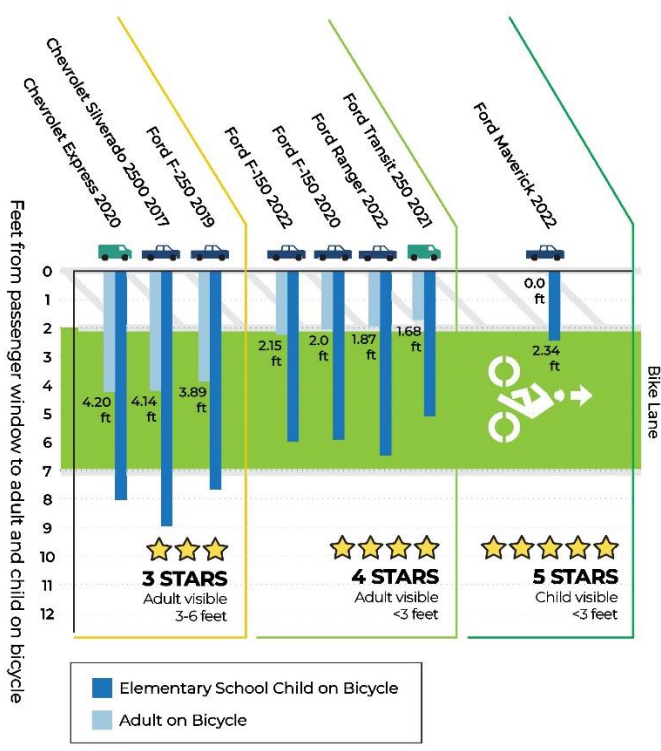
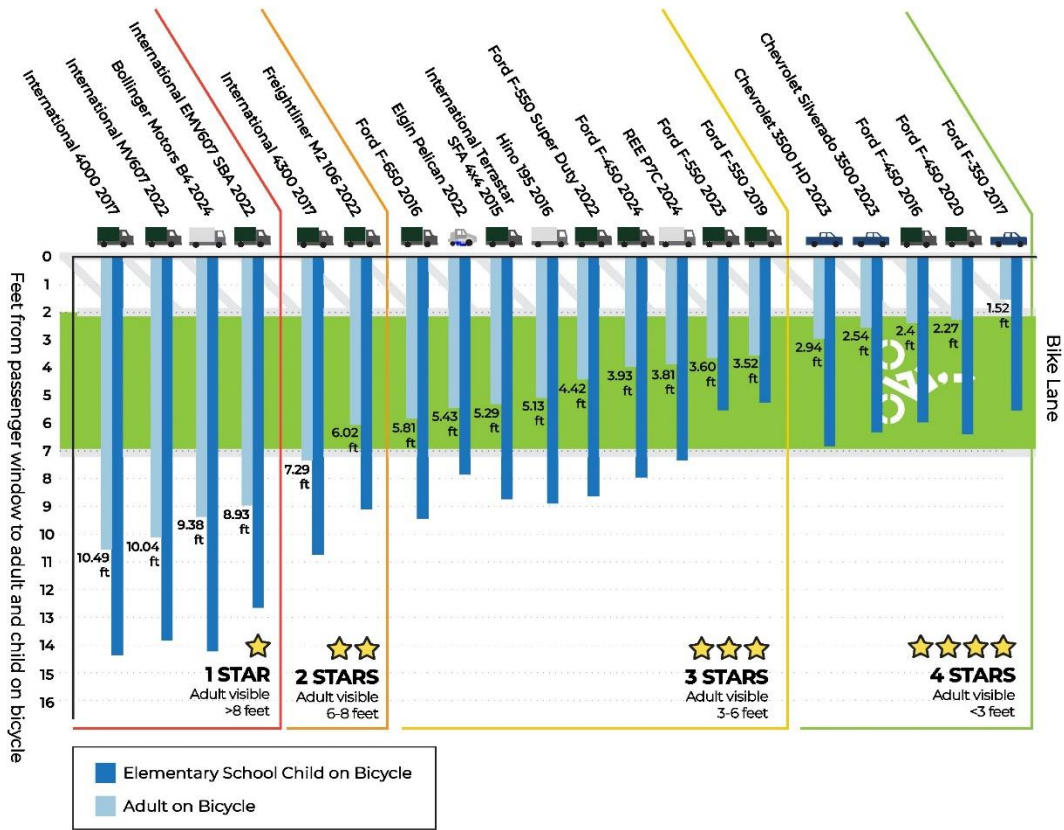

Figure 21. Nearest point at which an adult and child are visible to a driver at a buffered bike lane overlaid with a five-star rating system for measured medium-duty vehicles (top) and light-duty vehicles (bottom).

3.2 Countermeasures for low-vision trucks

Although there are safety benefits to procuring and maintaining high-vision vehicles, practical and fiscal limitations can sometimes mean that it is not realistic to *only* have high vision vehicles in the fleet. Fortunately, there are certain strategies and additions that can be employed to mitigate the risk of low vision vehicles. Two potential models for direct vision mitigation measures that Commonwealth Fleet Owners can consider applying are the Progressive Safe System³⁶ (PSS) and the Construction Logistics and Community Safety-Australia (CLOCS-A) recommendations.³⁷

Overview of Safe System requirements for zero star-rated vehicles:

1. Class V mirror must be fitted to the nearside of the vehicle
2. Class VI mirror must be fitted to the front of the vehicle
3. Side under-run protection must be fitted to both sides of the vehicle (except where this is impractical or proves to be impossible)
4. External pictorial stickers and markings must be displayed on vehicles to warn vulnerable road users of the hazards around the vehicle
5. A sensor system that alerts the driver to the presence of a vulnerable road user must be fitted to the nearside of the vehicle
6. Audible vehicle manoeuvring warning must be fitted to warn vulnerable road users when a vehicle is turning left
7. A fully operational camera monitoring system must be fitted to the nearside of the vehicle

HGV Safe System

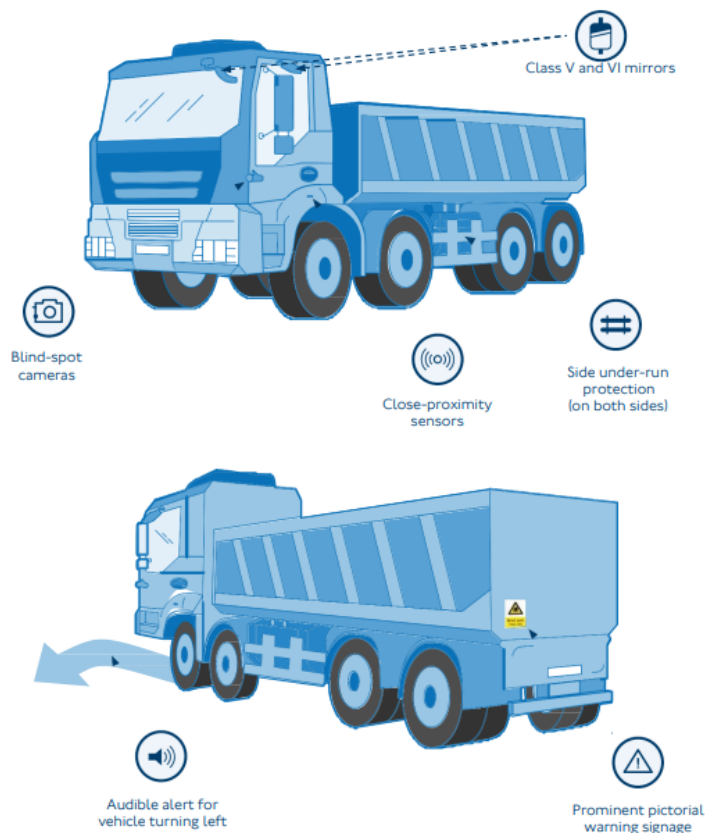

Figure 22. Overview of countermeasures from Transport for London Direct Vision Standard (for more details and specifications, see: <https://content.tfl.gov.uk/hgv-safety-permit-guidance-for-operators-entering-london.pdf>)

Transport for London’s DVS implementation requires countermeasures for low-vision trucks. Termed “Progressive Safe System,” the upgrade to the DVS star system requires HGVs over 12 tonnes with a star rating lower than three stars to be fitted with the new and updated system before applying for the HGV safety permit³⁸. TfL established seven requirements, including camera monitoring systems fitted at the

³⁶ [Direct Vision Standard and HGV Safety Permit Scheme - Transport for London \(tfl.gov.uk\)](https://content.tfl.gov.uk/hgv-safety-permit-guidance-for-operators-entering-london.pdf)

³⁷ <https://clocs-a.org.au/clocs-a-standard/>

³⁸ <https://content.tfl.gov.uk/hgv-safety-permit-guidance-for-operators-entering-london.pdf>

nearside (passenger side) of a vehicle, class V and VI mirrors fitted to the front and nearside of the vehicle, side guards, audible warnings when turning left (or right for left-hand drive vehicles), external warning signs that signal to other road users the hazards around the vehicle, and notably, two new sensor systems, the Blind Spot Information System (BSIS) and the Moving Off Information System (MOIS)³⁶.

Figure 22 shows these countermeasures for a standard dump truck, which include Class 5 and 6 mirrors, blind-spot cameras, close-proximity sensors that alert the driver, side guards, audible external alerts, and warning signage placed on the rear of the truck.

The Blind Spot Information System (BSIS) is a passenger side VRU detection system that can distinguish between stationary and moving objects, alerting drivers only when VRUs are detected rather than a car or roadside object (unless a collision with these items is imminent).³⁹ Tfl's performance requirements mandate that the system must detect VRUs from the vehicle's passenger side edge up to 2.2 meters laterally and 9 meters rearwards and activate information signals when a VRU is detected within said range, as shown in Figure 23.⁴⁰ Information signals can be delivered through various modes, such as audible (speech or tonal), haptic (vibration), or visual signals. In the case of increased collision risk, a *multimodal* warning signal must be issued, clearly distinct from the information signal.

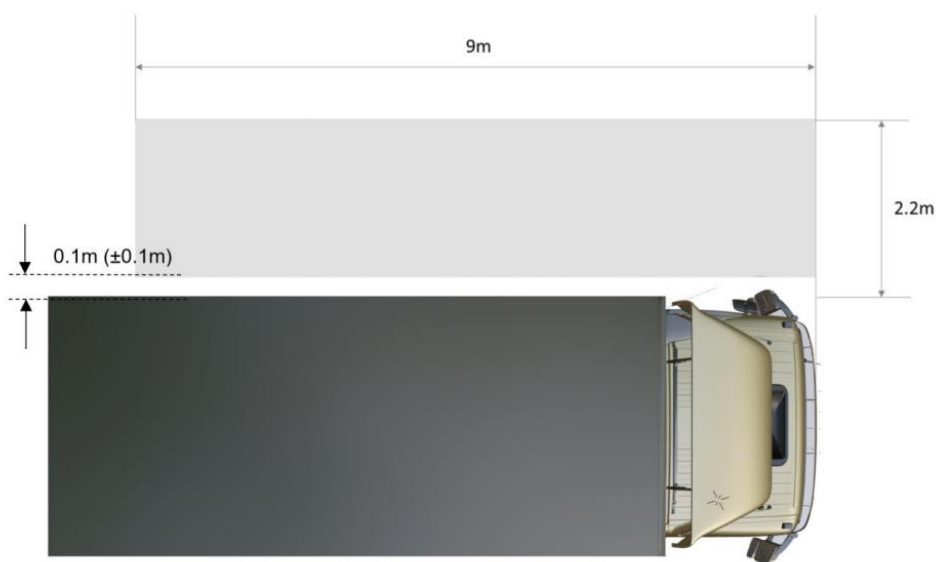

Figure 23. Diagram of BSIS's VRU detectable range (for more details and specifications).⁴¹

In addition, the Moving Off Information System (MOIS) is a sensor detection system fitted to the front of the vehicle that alerts the driver to the presence of a VRU when the vehicle starts moving.³⁹ Tfl's functional requirements for the MOIS specify that when a vehicle is stationary, the system must inform the driver of VRUs within or about to enter the critical blind spot area (d_w in Figure 24), as well as the

³⁹ <https://www.fleettrak365.co.uk/dvs/>

⁴⁰ <https://content.tfl.gov.uk/tfl-pss-technical-specification-bsis-acc.pdf>

⁴¹ <https://content.tfl.gov.uk/tfl-pss-technical-specification-bsis-acc.pdf>.

passenger side and driver side separation planes (d_{NSP} & d_{OSP} in Figure 24) through a visual signal.⁴² Like the BSIS, if the vehicle is preparing to move off, a higher intensity, multimodal warning signal must be issued to alert the driver of any imminent collision risk with VRUs. Notably, the system must be able to distinguish between stationary and moving-off maneuvers to ensure that a warning signal is not issued while the vehicle is completely at rest.

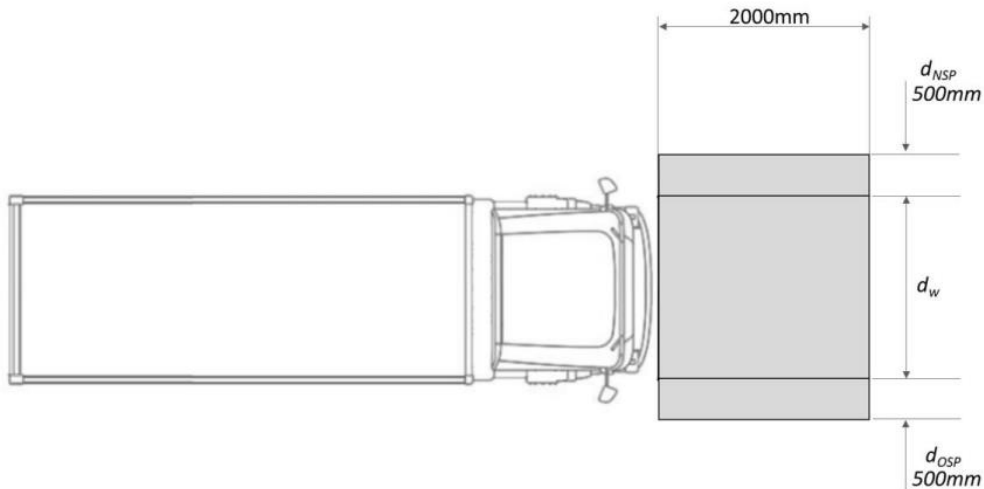

Figure 24. Diagram of MOIS's VRU detectable range (for more details and specifications).⁴³

Construction Logistics and Community Safety-Australia (CLOCS-A) is a program designed to manage the risks of construction projects on road logistics and safety.⁴⁴ Modeled from the UK-based CLOCS initiative, the CLOCS-A program recommends the installation of features to address a variety of safety concerns, such as telematics to monitor driver behaviors, and electronic stability control systems. The vehicle equipment requirements and restrictions are tiered into Bronze, Silver, and Gold compliance levels.⁴⁵ Although not a direct vision standard per se, CLOCS-A recommends features that enhance the direct vision of heavy vehicles, such as eliminating inappropriate sun visors and bug deflectors on conventional cab trucks and restricting any aftermarket accessories mounted in the cab (e.g., a GPS device) that would restrict the driver's field of view. In addition to recommendations on improving direct vision, CLOCS-A also provides suggestions as to how to improve indirect vision. For example, CLOCS-A recommends a Fresnel lens be attached to the passenger door window. Further, the standard suggests Class V mirrors (rectangular convex mirrors) and Class VI mirrors (circular convex mirrors) be attached above the passenger-side window and on the front of a truck hood respectively. Class VI mirrors are often referred to as "cross-over mirrors". (Note that the same 2022 Act to Reduce Traffic Fatalities that required this study also requires these cross-over mirrors for state-owned, leased, and contracted vehicles.)

⁴² <https://content.tfl.gov.uk/tfl-pss-technical-specification-mois-acc.pdf>

⁴³ <https://content.tfl.gov.uk/tfl-pss-technical-specification-mois-acc.pdf>

⁴⁴ <https://clocs-a.org.au/>

⁴⁵ <https://clocs-a.org.au/resources/ehicle-equipment-requirements-per-clocs-a-tier/>

3.3 Future exploration: area-based and volume-based methods of evaluating direct vision

Building on the City of Boston direct vision effort, this study employed a newly standardized blind zone measurement approach. In contrast to the prior study’s field measurements, the team collected blind zone area data for the forward 180-degree field of view for each vehicle, not only the NVPs in the 0- and 90-degree directions. This larger dataset creates opportunities for more nuanced direct vision assessment and potentially more robust future direct vision specifications.

Since a person walking, biking, or rolling may be present at any angle from the driver when the vehicle is driven forward, and since A-pillars, B-pillars, mirrors, hoods, and other visual obstructions can be present at various angles as well, an area- or volume-based approach could be refined and adopted in the future to more comprehensively assess risk. In its simplest form, this approach could quantify the percent of area visible to the driver within a relevant distance. Based on expected low collision speeds (e.g., 10 mph) in blind-zone relevant crashes such as start-up and turn crashes, and based on the associated distance that a driver travels during perception response time for braking and stopping the vehicle, a reasonable minimum radius may be 27 feet.

Braking/Stopping Distances

| MPH | Ft./Sec. | Braking Deceleration Distance | Perception Reaction Distance | Total Stopping Distance |
|-----|----------|-------------------------------|------------------------------|-------------------------|
| 10 | 14.7 | 5 | 22 | 27 |
| 15 | 22 | 11 | 33 | 44 |
| 20 | 29.3 | 19 | 44 | 63 |
| 25 | 36 | 30 | 55 | 85 |
| 30 | 44 | 43 | 66 | 109 |

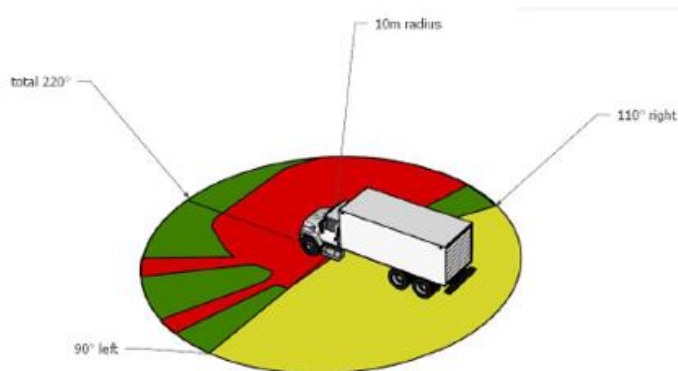

Figure 25. Pre-collision speeds and stopping distances, highlighting low-speed crash regime relevant to blind zone crashes between VRUs and large vehicles⁴⁶; Montreal approach to assess blind zone and visible area within 10 meters.

Adjusted for a safety buffer, one may apply a 10-meter (32.8 feet) radius as the critical visibility zone. This approach is similar to one that the City of Montreal has prototyped within the Quebec BNQ 1030-100 Safety of Heavy Vehicles Standards Committee.⁴⁷ Figure 26 shows representative overhead images for two heavy-duty vehicles, centered at the driver’s eyepoint, from which the visible and obstructed areas inside the 10-meter forward semicircle is considered.

In the forward 180-degree field of view for each of the study vehicles, Volpe determined the percent visible area at ground level using ArcGIS⁴⁸ and attempted to calculate the visible area at adult and child shoulder heights within a 10-meter radius of the driver. The results shown below for adult and child

⁴⁶ https://nacto.org/docs/usdg/vehicle_stopping_distance_and_time_upenn.pdf

⁴⁷ <https://bnq.qc.ca/en/standardization/protection-and-safety/safety-of-heavy-vehicles.html>

⁴⁸ Excluding the area of the vehicle footprint.

height visible areas are produced by code that Volpe adapted from an Olin College of Engineering student prototype [software tool](#); it generated results for some but not all vehicles and would require additional debugging and development before deploying at larger scale. However, even these illustrative results demonstrate that area metrics for direct vision could be used in combination with or in place of distance-based metrics to distinguish between vehicles for allowing the driver to see a VRU type of interest. The analysis could be segmented by weight class, similar to the distance-based results in Section 2.3.

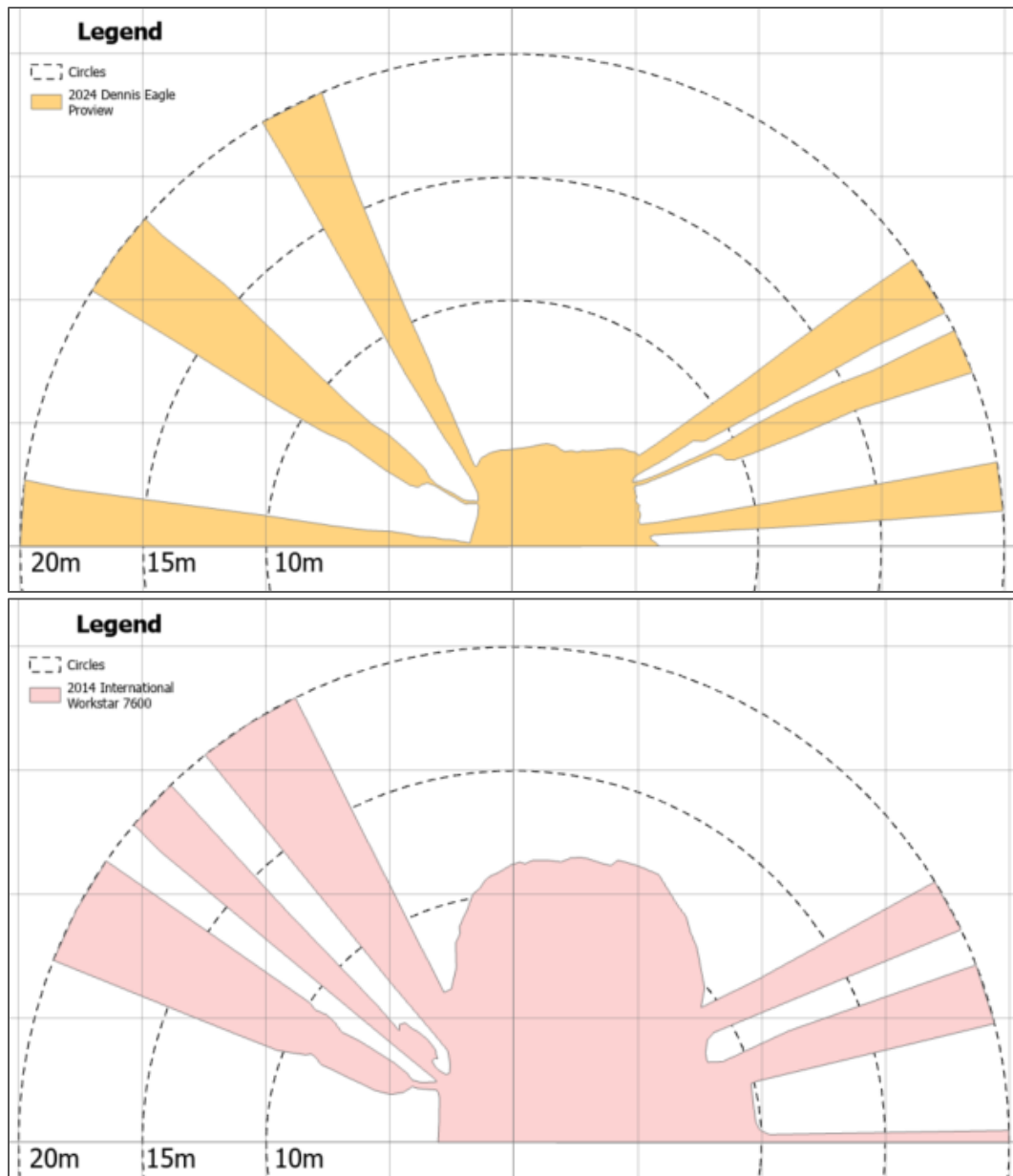

Figure 26. Blind zone comparison at ground of high vision and low vision Class 8 trucks (top: 2024 Dennis Eagle Proview; bottom: 2014 International Workstar 7600). Dennis Eagle Proview has 165 square meters of blind zone area at the ground level within a 20 meter radius; International Workstar 7600 has 285 square meters of blind zone area at the ground level.

While ground-level visible area is indicative of a driver's direct vision to pavement markings and to the entirety of a pedestrian or other VRU, an area-based measurement approach is more directly related to

direct vision safety when based on visible area at the shoulder heights of VRUs of interest.

From the markerless method that produces the area analyses described above, visible and blind volumes could also in principle be computed and used in analysis, like the underlying volumetric criteria used in the TFL and UN R167 standards. This approach has not been undertaken in the present study due to scope and tool constraints, given that the software used in this study does not currently compute volume, though this warrants consideration in future analysis.

Figure 27 through Figure 29 show the area-based results for the 57 study vehicles with processed data. In general, vehicles exhibit high or low visibility under both methods, but the area-based calculations show a different order for visibility. The area-based calculations are heavily weighted by A pillars and areas obscured by mirrors, so any differences are likely due to these design factors. As examples, the Peterbilt 348 and International HV507 have relatively higher visibility using the area-based method. Alternatively, the Mack Granite GR42F and Freightliner 114SD have relatively lower visibility using the area-based method.

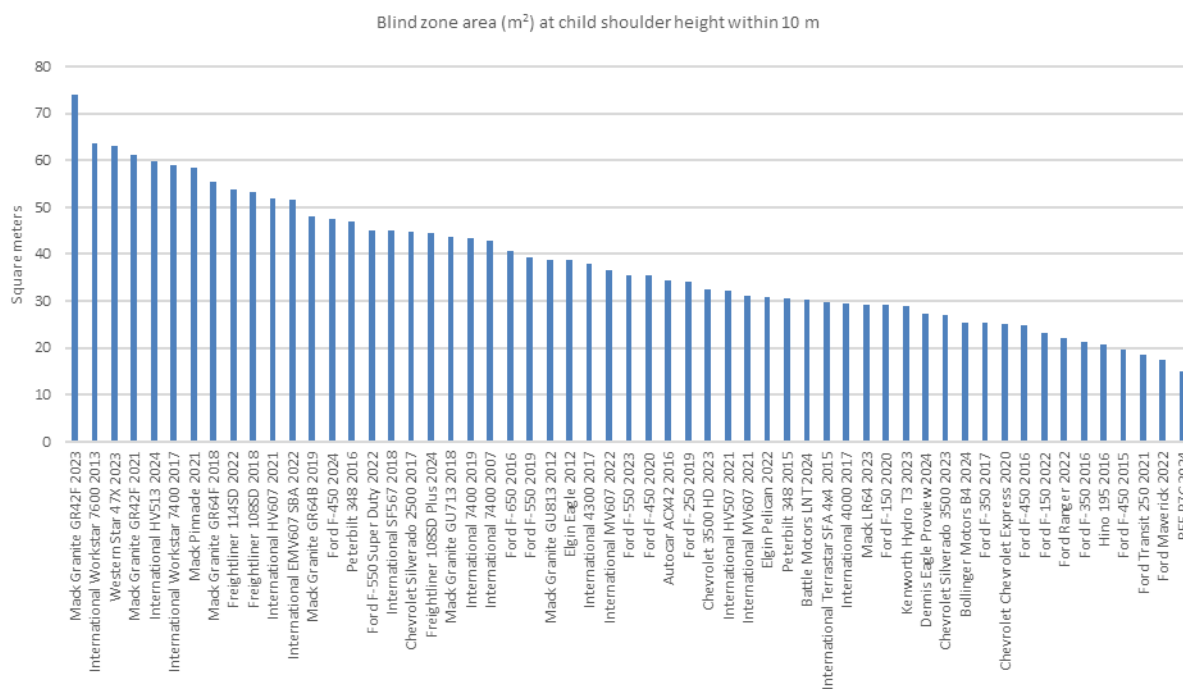

Figure 27. Blind zone area (square meters) at child shoulder height within a 10-meter radius of driver.

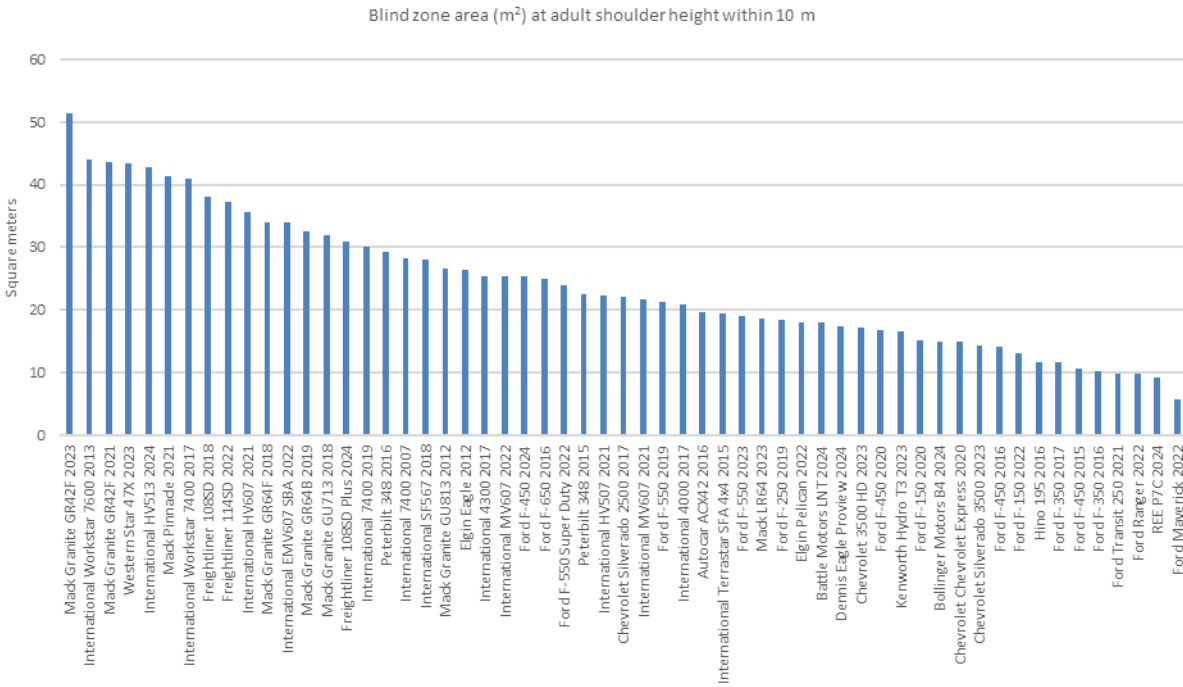

Figure 28. Blind zone area (square meters) at adult shoulder height within a 10-meter radius of driver.

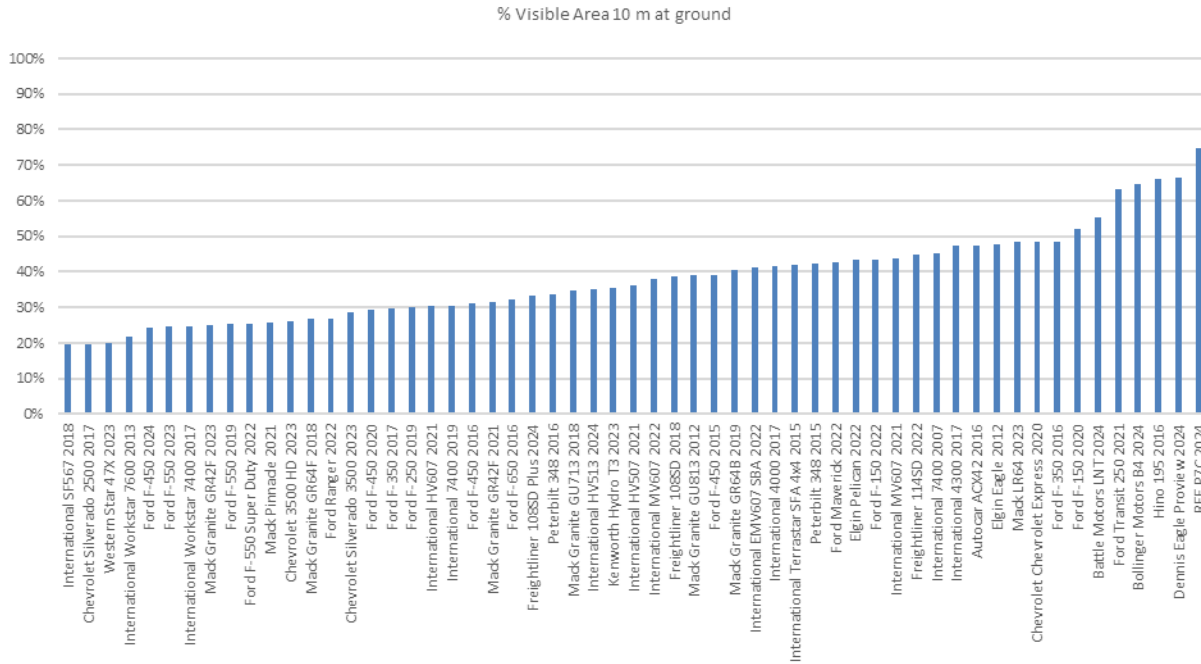

Figure 29. Percentage of ground visible within a 10-meter radius of the driver.

3.4 Incorporating direct vision in procurement

High vision vehicles are only helpful to advancing a Safe System to the extent that they are deployed on the road. The Commonwealth of Massachusetts is positioned to potentially leverage its buying power to ensure that agencies, municipalities, and contractors prioritize procuring direct vision vehicles.

There are several options for increasing the adoption of direct vision vehicles across the Commonwealth. For example, language could be included in the VEH111 contract for Heavy Duty Vehicles, Road Maintenance, and Construction Equipment⁴⁹. In the current iteration of VEH111, the contract allows for departments to purchase Environmentally Preferable Products that could encompass alternative fuels, biofuels, and batteries. A similar section on direct vision (or more broadly, safe design) could be included, prompting relevant parties to purchase direct vision vehicles whenever possible. Relatedly, there is also a unique opportunity to combine the priorities of electrification and direct vision. Trucks without an engine block (i.e., electric batteries are integrated into the bottom of a vehicle) can have improved direct vision compared to conventional cab diesel trucks, meaning that road safety and electrification are linked.

In addition, requiring fleet managers to report the proportion of their fleet that can be categorized as high vision could also encourage the procurement of a greater number of direct vision cabs. Further, as mentioned above in Section 3.2, due to specialized requirements or other limitations, it might not always be possible to obtain high vision vehicles. Therefore, a “Safer Fleet Program” could be established that details a) when direct vision cabs should be prioritized and b) what mitigation measures should be put into place should a high vision vehicle be unable to replace a low vision vehicle (e.g., installing blind spot detection equipment and signage indicating low visibility to other road users).

Beyond encouraging Commonwealth agencies and municipalities to prioritize high vision vehicles, the Commonwealth of Massachusetts can build partnerships and coalitions with organizations across the Nation to advocate for direct vision implementations. Both nonprofit groups (e.g., TSR, IIHS, and National Association of City Transportation Officials) and municipalities (e.g., New York City, Portland, OR, and Boston) have signaled interest in increasing the adoption of high visibility vehicles. Further, manufacturers have started to specifically incorporate direct vision into their designs to enhance road safety. Examples include Dennis Eagle, Freightliner, Mack, Oshkosh, Battle Motors, Volvo, and REE, and electric models may increasingly offer high vision options. Partnering with these organizations and companies can enhance the reach of Massachusetts’ efforts and establish the Commonwealth as a national leader on direct vision.

3.4.1 Document and Language Options

Volpe reviewed the Commonwealth’s procurement system for recent vehicle purchases and identified

⁴⁹ [download \(mass.gov\)](#)

three potential options to incorporate direct vision criteria:

The following are two options for language that the State or municipalities could use for requiring minimum direct vision. It would alert potential bidders to this requirement and link to a specification that they could reference.

Option 1

The Commonwealth could state:

- “The vehicle complies with the MassDOT direct vision specification [LINK TO BE ADDED]”
 - Note: The direct vision specification would link to a summary of the rating system described in Section 3.1.

Option 2

If it is possible to request and collect numeric responses from bidders, request VRU distances instead of yes/no. Some vehicles may be close to the minimum criteria, and some may be far off. A numeric response would offer the Commonwealth more information in choosing vehicles.

- “The forward distance to a child pedestrian’s 37-inch shoulder height is: _____”
- “The passenger side distance to an adult bicyclist’s 47-inch shoulder height is: _____”

If this option is chosen, the instructions could direct the person conducting the measurements to follow the MassDOT/IIHS standard operating procedure, including standardized driver eyepoint.

Accompanying any of these options, the Commonwealth could require provision of blind zone countermeasures on certain vehicles, which the Commonwealth could specify to include mirrors and side guards, as already prescribed by State regulation, in addition to the safe system requirements that Tfl’s DVS requires for zero-star vehicles.

- “If the vehicle does not comply with the Commonwealth direct vision specification, the vehicle is equipped with specified blind zone safe system countermeasures.”

3.4.2 Proposed Reporting Method

The following proposed direct vision reporting method, consistent with the language Option 2 above, represents a near-term implementable approach. This physical, traffic cone-based reporting method could potentially allow the Commonwealth to test and implement a procurement policy within months by limiting the burden on bidders and aiding in independent verification.

The method relies on two traffic cones or other objects of specific heights, a tape measure or laser range finder, two individuals, and an IIHS-type rig or other device that can set a specific eye-height and position. Bidders would measure how far forward and to the passenger side the median height male driver can see a given VRU from the vehicle, using a standardized measurement rig with a phone camera mount.

When the seat is in the mid-height, mid-track position and an IHS-type rig or other device that can position a camera lens at a height of 80.4 cm (31.7 inches) directly above the rear of the seat pan:

- Request the distance forward of the center of the vehicle bumper at which the camera can first see the top of a 3-foot cone. This is the forward distance to a child VRU.
- Request the distance beyond the exterior of the passenger side door at which the camera can first see the top of the 4-foot cone. This is the passenger side distance to an adult VRU.

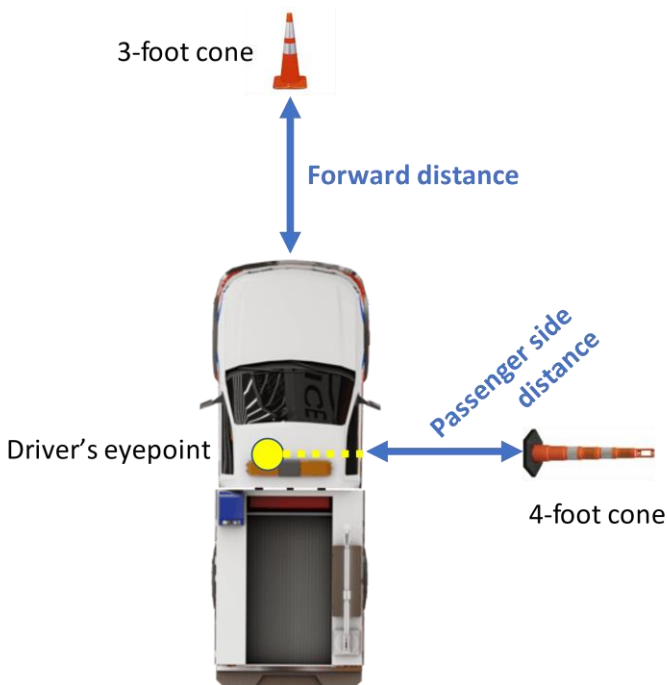

Figure 30. Proposed near-term cone method of direct vision reporting for bidders.

By incorporating a modest data collection request into the method, rather than a binary yes/no answer, Volpe anticipates this approach would, over time, enable broader analysis of vehicle options on the U.S. market.



Figure 31. Setup for 3-foot and 4-foot cone method of blind zone measurement.

3.5 Future work

Given that the vehicles on the roads have the direct vision levels they currently have, MassDOT could consider complementary Safe System Approach strategies through safe road design that could mitigate the presence of large vehicle blind zones at key locations.

Separating VRUs far enough apart to be positioned out of any vehicle's blind zones can be a design solution, but it is not always possible to widen rights-of-way, and there are tradeoffs of doing so. However, there is a significant toolkit of potential geometric, design, and operational strategies that could potentially mitigate blind zone risk of low-vision vehicles. These strategies have not been widely studied, as driver sightline analysis in geometric design and traffic engineering commonly focuses on long-distance visibility or visibility to the legs of an intersection, and not on the proximate visibility within 10 or 20 meters of a vehicle at an intersection. Potential strategies to position road users in space and time to help keep VRUs safely out of blind zones include:

- **Geometric design**
 - Protected intersections
 - Offsets
 - Raised crosswalks, bike lanes, and tables
- **Pavement markings**
 - Advance stop lines
 - Two-stage left boxes
 - Daylighting
- **Traffic control devices**
 - Near-side traffic signals
 - NTOR policy
 - LPI or exclusive ped phase
- **Modal priority networks**
 - Safe Routes to School
 - Bike networks
 - Truck routes



Figure 32. Illustrations of different geometric designs at intersections and crosswalks: a) protected intersection, b) raised crosswalk, c) near-side traffic signals, and d) advance stop line.

Potential administrative approaches to implementing such strategies could include consideration of how controlling criteria⁵⁰ in state-funded transportation projects are applied and refined, including through any potential future guidance. In a similar way to how speed and volume currently determine the required level of bicycle lane separation, context such as truck route, school zone, or predominance of truck traffic in the vicinity of biking and walking modal networks could be used as inputs to lateral, longitudinal, and temporal separation from blind zones. Alternatively, roadways with a High Potential for Walkable Trips, as defined in the latest version of the Massachusetts Pedestrian Transportation Plan, and all roadways classified as a corridor with a High Potential for Everyday Biking,⁵¹ as defined in the Massachusetts Bicycle Transportation Plan, could be compared to truck volumes and used to prioritize potential design, engineering, or policy interventions (e.g., truck restrictions) and locations.

Example existing MassDOT planning resources that could assist in site selection or design include the following figures.

⁵⁰ <https://www.mass.gov/doc/controlling-criteria-and-design-justification-process-for-massdot-highway-division-projects-e/download>

⁵¹ <https://massdot.maps.arcgis.com/apps/webappviewer/index.html?id=371274be470c4f9db0543943398eb3d3>

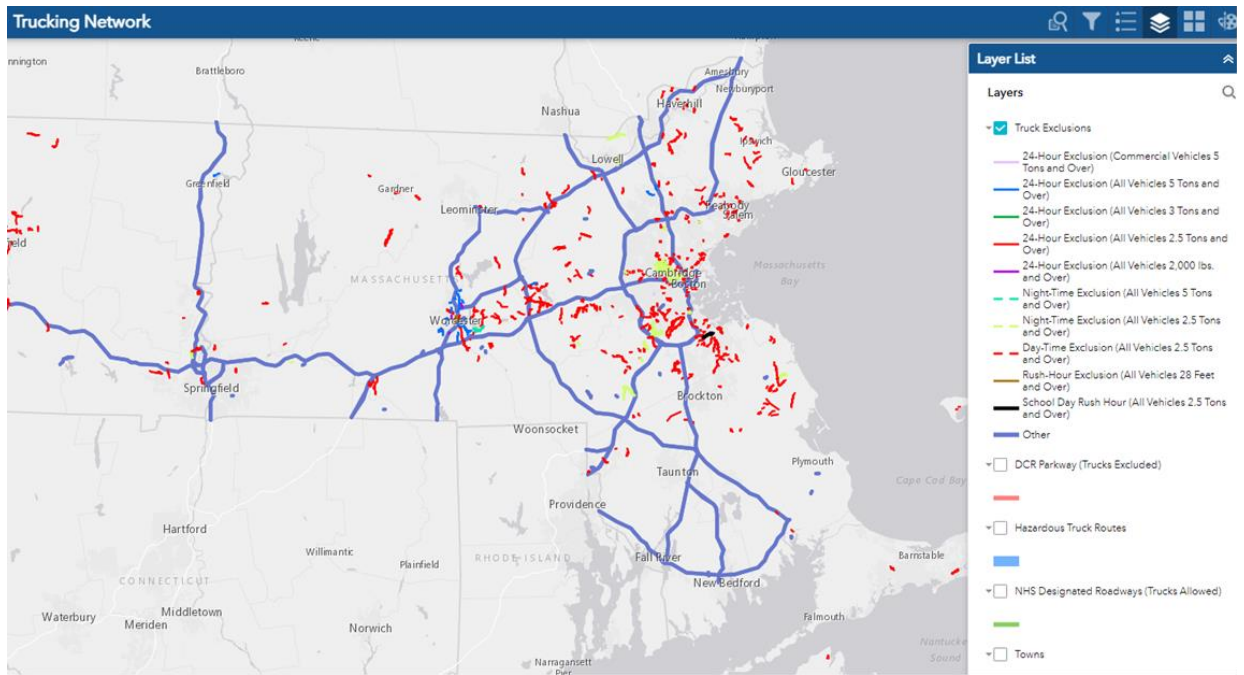

Figure 33. MassDOT Trucking Network, with layers shown for truck exclusions.⁵²

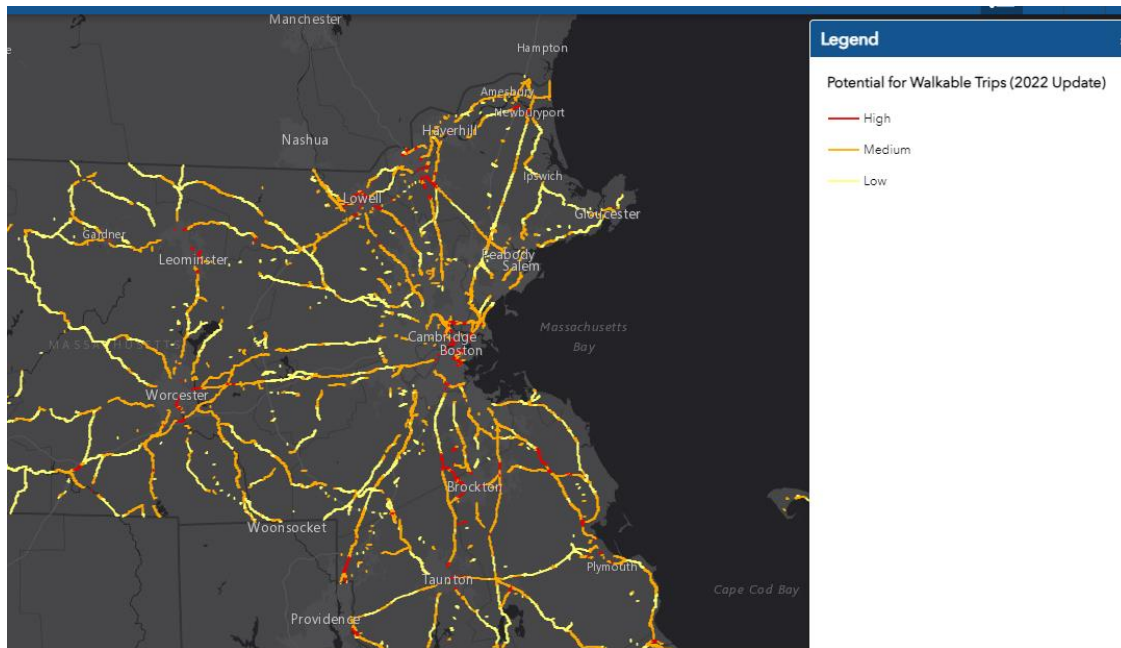

Figure 34. MassDOT Potential for walkable trips on MassDOT roads (2022 update).⁵³

⁵² <https://massdot.maps.arcgis.com/apps/webappviewer/index.html?id=2a5e4a25a26d4e2b9e90eac33bea712f>

⁵³ <https://massdot.maps.arcgis.com/apps/webappviewer/index.html?id=908cf743da4340d3bf2f02a17fc5cc69>

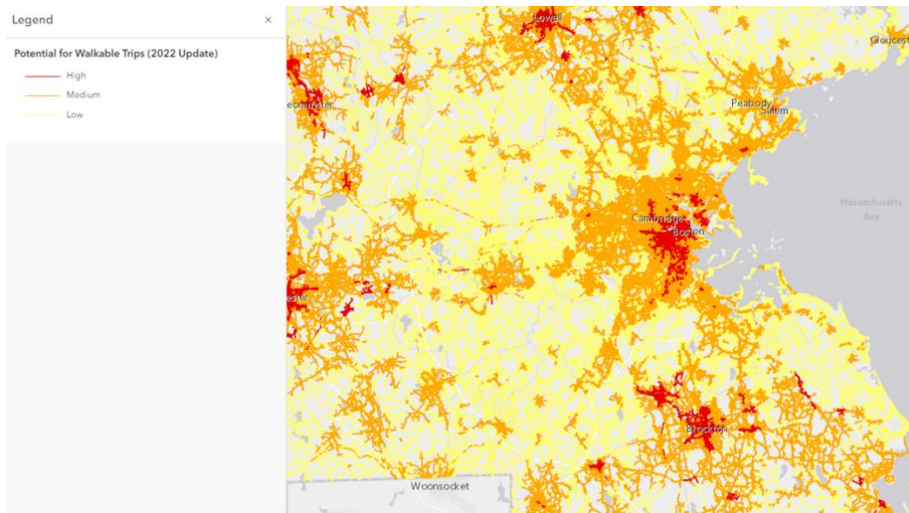

Figure 35. MassDOT potential for everyday walking on MassDOT roads.⁵⁴

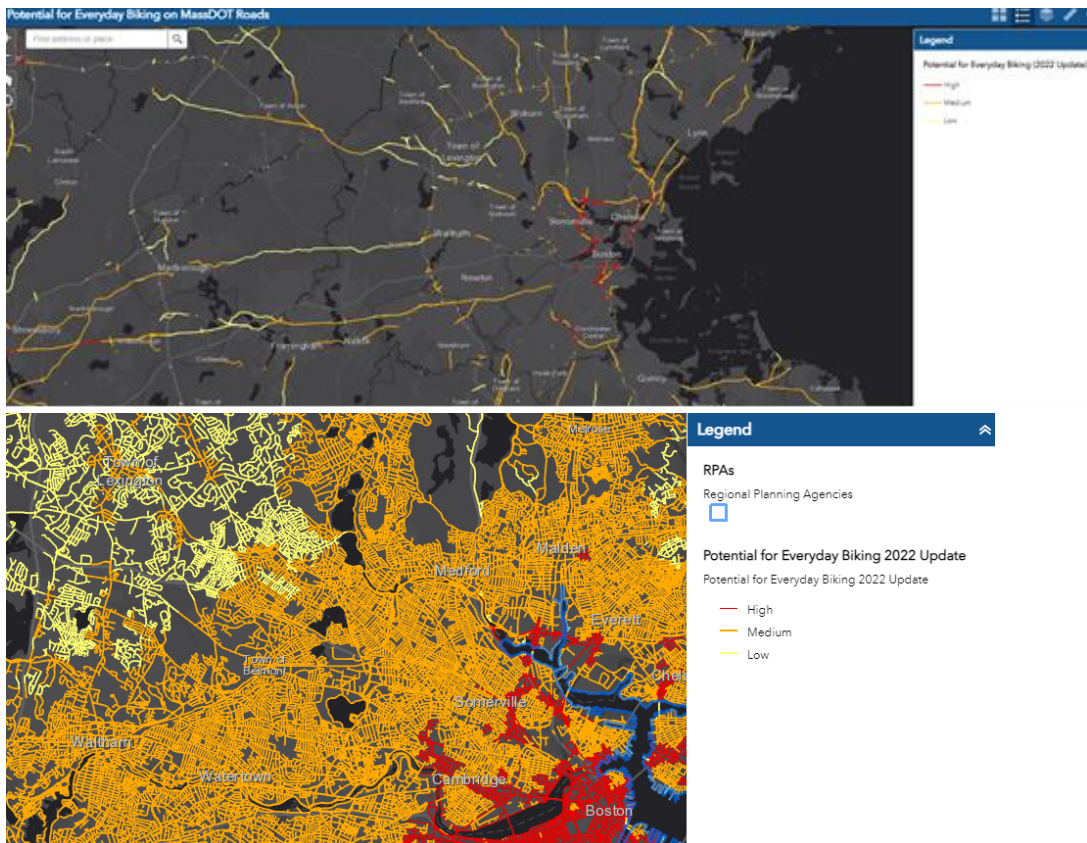

Figure 36. Potential for Everyday Bicycling map on MassDOT and all roads (top: Eastern MA; bottom: zoom in around Cambridge-area).⁵⁵

For interventions at identified sites, the typical or worst-case blind zones of design vehicles could be considered. Existing design workflows calculate swept paths and turn radii and apply these to geometric

⁵⁴ <https://massdot.maps.arcgis.com/apps/mapviewer/index.html?layers=4f36acded5c14bd69d519d47f949e451>

⁵⁵ <https://massdot.maps.arcgis.com/apps/webappviewer/index.html?id=a1c48137a3c642c19b749e16ec509d3c>

design for capital or quick-build street projects. In a similar manner, analysis of blind zone paths could identify where conflicts may call for separation strategies. A notional example of how site-specific design vehicle blind zones can be dynamically simulated is shown in the AutoTURN Pro software screen capture below.

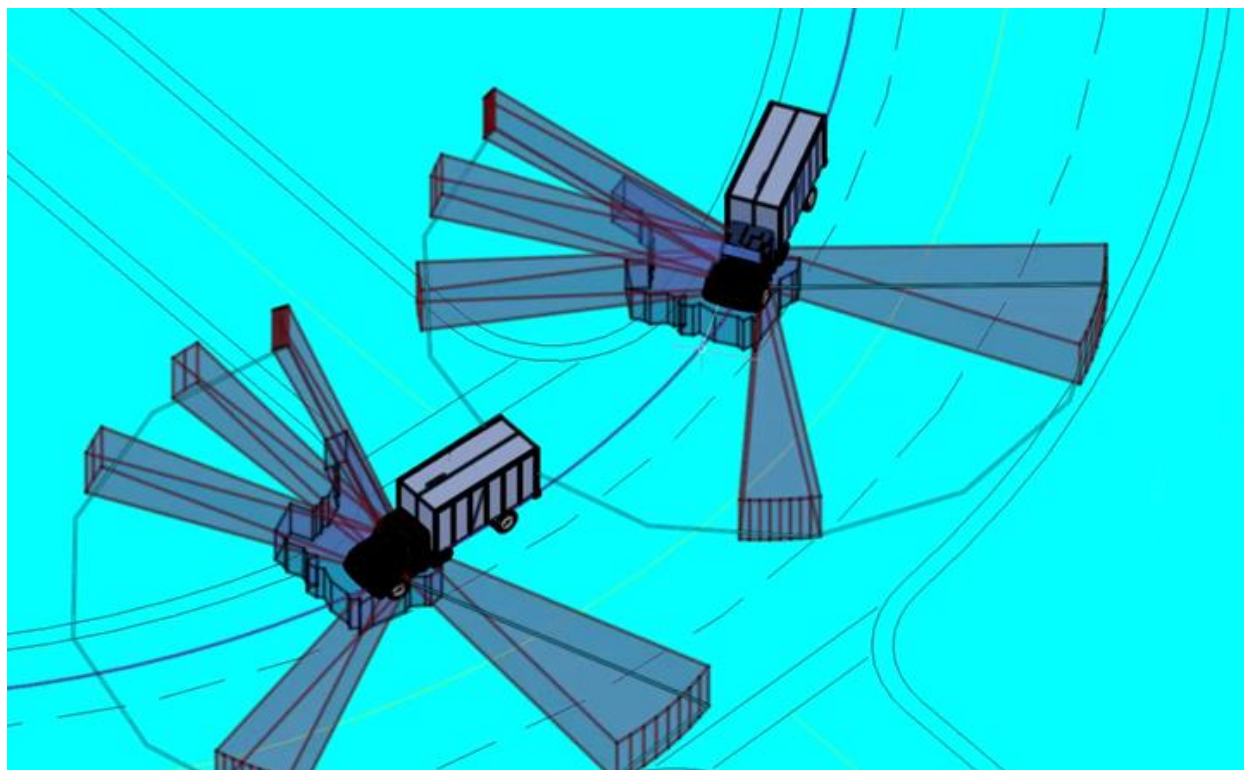

Figure 37. Example of swept path visibility safety analysis for a design vehicle through an intersection that could use data from studies such as this one to model blind zone risk to people outside of vehicles and inform geometric, engineering, or operation countermeasures. (Courtesy: AutoTURN / Transoft Solutions)

This study identified future research, policy, and socialization steps to advance toward adoption of higher vision vehicles and reduced blind zone risk to people walking, rolling, and biking.

Research needs include:

- Streamlined data collection (e.g., fewer photos) to increase scalability of the markerless method
- Further testing and assessment of the lidar measurement method
- Automated data processing for accurate measurement of a larger number of vehicles
- Code development and validation for area- or volume-based direct vision methods
- Measurement of additional makes and models on the market for a comprehensive database
- Assessing the safety benefits of countermeasures for low-vision vehicles, including but not limited to bird's-eye view cameras and moving off information systems

Potential policy steps include:

- Examine current Commonwealth and other State authority opportunities and potential gaps
- Consider how local (e.g., Seattle DOT) or State (e.g., MA hazmat rule) truck permitting and access program frameworks could be used to support large vehicle safety goals

Socialization steps include:

- Present at conferences and to professional organizations
- Develop and deploy surveys to fleet owners and managers to assess current understanding of, or future interest in, fleet Direct Vision measurement and improvement
- Prepare letters and articles sharing the findings of this study with relevant professionals

4 Appendix

4.1 Data collection SOP

Markerless Rig Setup and Data Capture (adapted from IIHS)

EQUIPMENT CHECK

- Measurement rig with 50th male neck assembly and camera turntable Quad Lock mount
 - Verify that camera lens at 80.4 cm height when mounted and when neck is vertical
- Bosch Blaze laser tool
- Laser target (sign holder stand)
- Camera phone (iPhone 12) in Quad Lock case
- Camera shutter Bluetooth remote

VEHICLE SETUP

- Place vehicle on a reasonably flat and level ground surface with space in front of the vehicle that creates a clear contrast from the ground and the hood line of the vehicle.
- **Record vehicle year, make, model and VIN information in Excel.** Take photo of VIN and front of vehicle for reference.
- When possible, set steering column to fully stowed and approximately mid tilt.



Figure 38. Steering column placement for data collection.

SET DRIVER SEAT

50th Male Midtrack – Midheight Position

- Set driver seat to lowest vertical height. Note, non-power seats typically have a lever that pumps to lower or raise seat height.



Figure 39. Seat adjustment control buttons.

- Install seat target on floorboard of vehicle and align laser measuring device on seat, ensuring the laser is forward and projecting onto the floorboard target setup. Lateral location on the seat is not important. Ensure the laser is stable and will not shift as the seat is moved.



Figure 40. Laser being used to identify the exact mid-point for seat, which will be used for rig placement and data collection.

- Move driver seat to forward most longitudinal position and **record distance in Excel.**
- Move driver seat to rearward most longitudinal position and **record distance in Excel.**
- **Compute midtrack distance in Excel.**
- Position the seat at midtrack. Hold the laser vertically on the seat pan pointing at the ceiling. Avoid sunroof, ceiling light, or other non-flat portions of the ceiling. From midtrack, use the vertical seat adjustment and record values of the **lowest and highest seat position in Excel.** If the seat begins to move forward as it moves up, allow it to do so, do not readjust rearward. **Calculate mid height in Excel** and adjust the seat down to that height.

POSITION MEASUREMENT ASSEMBLY

- Set measurement rig on the seat.

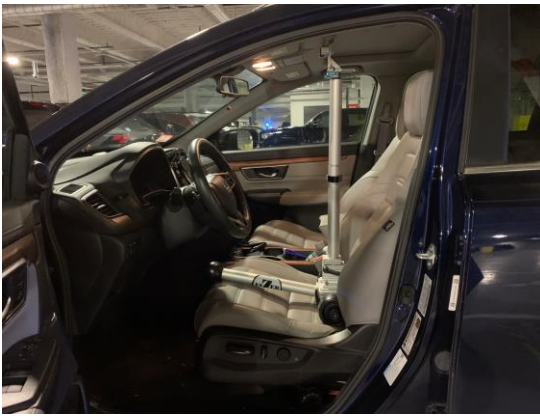

Figure 41. Rig placed in driver seat.

- Check that rig is squarely positioned against the seat back and centered in the seat.

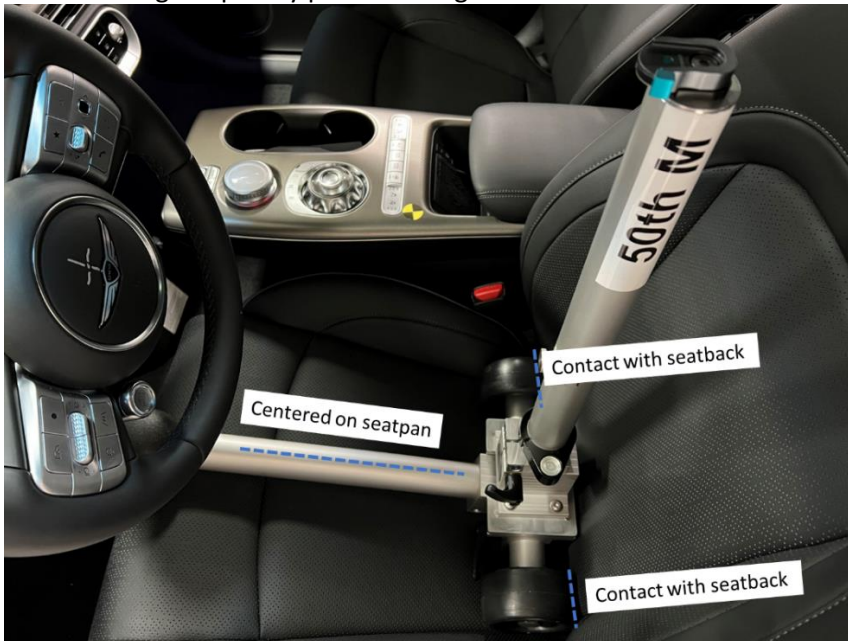

Figure 42. Rig with placement directions for seatback arrangement.

- Recline vehicle seat back. It is OK if the rig no longer touches the seatback when reclined.
- Hold long edge of the Bosch laser tool against the front face of the neck assembly and adjust the neck orientation to be within 1 degree of vertical. Do the same holding the Bosch level tool against the side face of the neck assembly.

MEASUREMENTS OF ASSEMBLY RELATIVE TO VEHICLE

- Install phone in the Quad Lock mount on top of rig.



Figure 43. Close-up of rig with phone installed for measurement.

- Set the laser target on the ground at the left front of the vehicle at ground level (the “origin”)
- Record in Excel the location of camera lens in reference to the origin: **lateral distance (x)**, **longitudinal distance (y)**, and **vertical distance from ground (z)** using the Bosch tool.
 - Note: x and z are positive values, but y is negative.

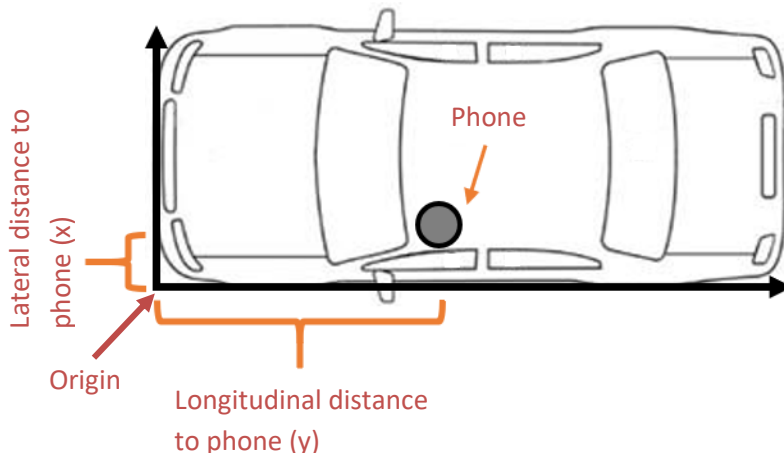

Figure 44. Overhead view showing the different distance calculations recorded during data collection process.

CAMERA-BASED MEASUREMENT COLLECTION

- Open camera app. Set camera to **0.5x magnification**.

- Do another check that the camera is mounted level, by checking that the yellow camera level is showing 0 ± 1 degree on the screen. Do this with the camera facing forward 0° and facing the passenger side 90° .



Figure 45. Image showing how to prepare vehicle for data collection process.

- If camera is not showing 0 ± 1 degree, you may make adjustments to the rig to level the camera, as in placing cardboard pieces under the legs of the rig or pushing on the rig slightly to achieve level.
- Use Bluetooth remote to take photos without having to climb into the vehicle.
- Take first photo at 0 degree position (facing forward).

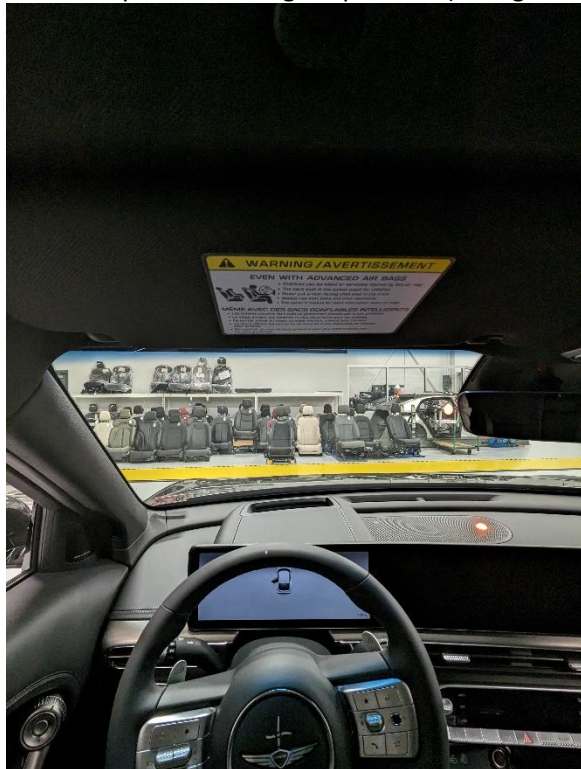

Figure 46. Example image at 0 degrees forward from driver eyepoint.



Figure 47. Rig shown at close range to show the method to rotate and line up the phone into the rig.

- Rotate in a clockwise direction, taking photos every 30 degrees (two turntable clicks) until the rightmost visible area is captured (90 degrees for most large trucks)
- Return to 0 degrees (straight ahead) and continue to rotate in a counterclockwise direction, taking photos every 30 degrees (two turntable clicks) until the leftmost visible area is captured (-90 or -120 degrees for most large trucks)
 - Be sure to close any doors that appear in the photo.
- After field collection, organize photos into separate folders for each vehicle, and rename photos to include the angle in the filename (e.g., 30.jpg)

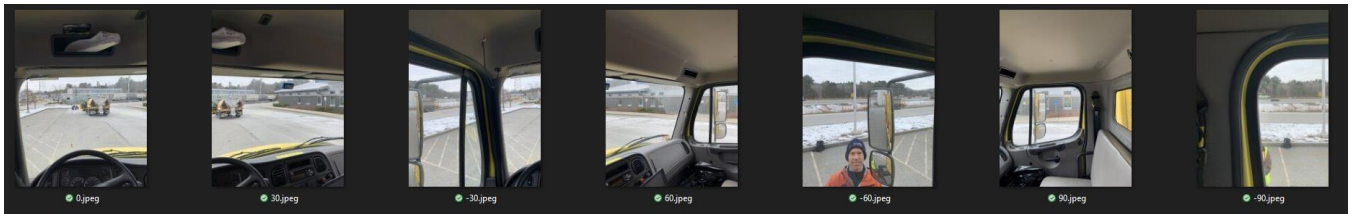

Figure 48. Aggregated images of the forward field of view for one vehicle.

4.2 Data processing details

This section shows the steps to complete the data processing. This begins with uploading and annotating images at each degree marker around the forward field of view. Then it includes ArcGIS clean-up steps to remove any duplicate nearest visible points at the same area around the vehicle. The final product is a single shapefile of the full blind zone at the ground level nearest visible points.

The section below contains these images at -60 degrees, -30 degrees, 0 degrees, 30 degrees, and 60 degrees with the annotations, and the resulting point-data showing the nearest visible point.



Figure 49. Image at 0 degrees where the right side of driver A pillar to midway across front hood is annotated.



Figure 50. Image at -30 degrees where the left side of driver a pillar plus mirror is annotated.



Figure 51. Image at -60 degrees where the annotation finishes the rest of driver window. Note that this may need to go to -90 or -120 degrees for some vehicles.



Figure 52. Image at 30 degrees where the annotation finishes the driver hood with some overlap and left side of passenger A pillar.



Figure 53. Image at 60 degrees where the entire passenger window is annotated.

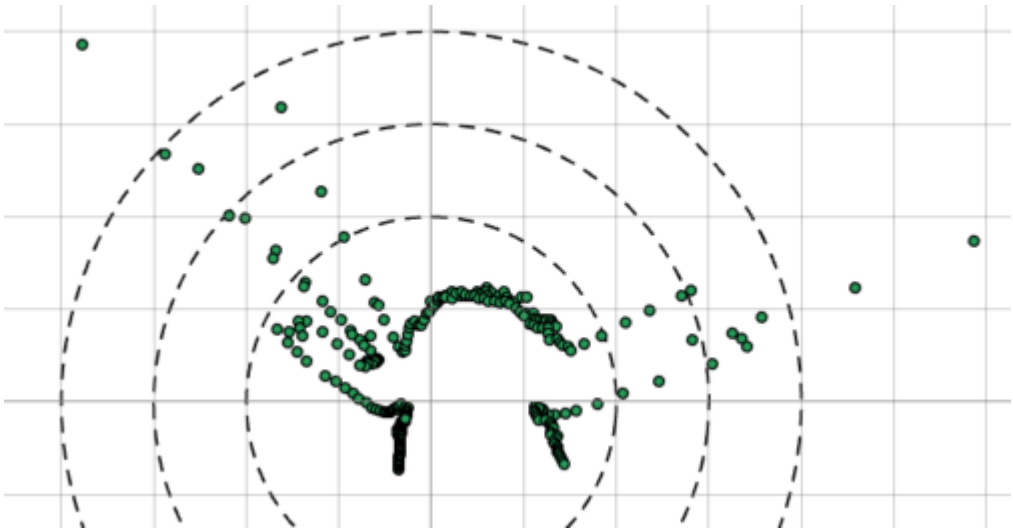

Figure 54. Raw output of nearest visible points on the ground around the vehicle. These are further processed to remove duplicate data points and aggregate into a single polygon shapefile of the vehicle blind zone.

4.3 An Act to Reduce Traffic Fatalities

In 2022, the Massachusetts state legislature passed the Act to Reduce Traffic Fatalities, and it was signed into law in January 2023.⁵⁶ The relevant sections are included below for reference.

SECTION 9. Section 7 of said chapter 90, as so appearing, is hereby amended by inserting after the fourth paragraph the following 2 paragraphs:-

A motor vehicle, trailer, semi-trailer or semi-trailer unit classified as a class 3 or above by the Federal Highway Administration, with a gross vehicle weight rating of 10,001 pounds or more, that is leased or purchased by the commonwealth on or after January 1, 2023, shall be equipped with a lateral protective device, convex mirrors, cross-over mirrors and backup cameras. This paragraph shall not apply to an ambulance, firefighting apparatus, low-speed vehicle, agricultural tractor or any other class or type of vehicle as determined by the registrar. The registrar shall adopt regulations establishing standards, consistent with the United States Department of Transportation John A. Volpe National Transportation Systems Center's side guard standard DOT-VNTSC-OSTR-16-05, and specifications for the size, design and mounting of lateral protective devices, convex mirrors and cross-over mirrors. The registrar may provide alternative means of compliance with the convex mirror, cross-over mirror and lateral protective device requirements.

The registrar shall prohibit: (i) visual obstructions due to aftermarket modifications and accessories that reduce the ability of the vehicle operator to directly see vulnerable users in the vicinity of the vehicle, including, but not limited to, bug deflectors and chrome visors; and (ii) aftermarket modifications and accessories that increase fatality and serious injury risk to vulnerable users in a collision with the vehicle, including, but not limited to, bull bars. The registrar shall promulgate regulations enforcing this paragraph.

SECTION 10. Said section 7 of said chapter 90 is hereby further amended by striking out the fifth and sixth paragraphs, inserted by section 9, and inserting in place thereof the following 2 paragraphs:-

A motor vehicle, trailer, semi-trailer or semi-trailer unit classified as a class 3 or above by the Federal Highway Administration, with a gross vehicle weight rating of 10,001 pounds or more, that is leased or purchased by the commonwealth on or after January 1, 2025, or operated under a contract with the commonwealth on or after January 1, 2025, shall be equipped with a lateral protective device, convex mirrors, crossover mirrors and backup cameras. This paragraph shall not apply to an ambulance, firefighting apparatus, low-speed vehicle, agricultural tractor or any other class or type of vehicle as determined by the registrar. The registrar shall adopt regulations establishing standards, consistent with the United States Department of Transportation John A. Volpe National Transportation Systems Center's side guard standard DOT-VNTSC-OSTR-16-05, and specifications for the size, design and mounting of lateral protective devices, convex mirrors and crossover mirrors. The registrar may provide alternative means of compliance with the convex mirror, crossover mirror and lateral protective device requirements. A contractor's failure to comply with this paragraph may be grounds for termination of

⁵⁶ <https://malegislature.gov/Laws/SessionLaws/Acts/2022/Chapter358>

the contract and may be punishable by a fine of not more than \$500 for the first offense and not more than \$1,000 for a second or subsequent offense.

The registrar shall prohibit: (i) visual obstructions due to aftermarket modifications and accessories that reduce the ability of the vehicle operator to directly see vulnerable users in the vicinity of the vehicle, including, but not limited to, bug deflectors and chrome visors; and (ii) aftermarket modifications and accessories, including, but not limited to, bull bars, that increase fatality and serious injury risk to vulnerable users in a collision with the vehicle. The registrar shall promulgate regulations implementing this paragraph.

SECTION 15. Not later than 6 months after the effective date of this act, the Massachusetts Department of Transportation shall initiate with the United States Department of Transportation John A. Volpe National Transportation Systems Center a study of the direct vision performance of the vehicles subject to the fifth and sixth paragraphs of section 7 of chapter 90 of the General Laws, as inserted by sections 9 and 10 of this act; provided, however, that the study shall be completed not later than 18 months after the effective date of this act. The study shall identify the range of direct vision afforded to drivers in this population of vehicles and produce evidence-based safety recommendations stipulating a minimum acceptable level of direct vision to be met by future applicable vehicles purchased and leased by the commonwealth. The study shall be submitted in a report to the clerks of the house of representatives and senate and the joint committee on transportation not later than 18 months after the effective date of this act.

U.S. Department of Transportation
John A. Volpe National Transportation Systems Center
220 Binney St.
Cambridge, MA 02142-1093

617-494-2000
www.volpe.dot.gov

DOT-VNTSC-MADOT-24-01